

## FOCUS

# Fishery science: analysis and present situation

**Carles Bas\***

Secció de Ciències Biològiques, Institut d'Estudis Catalans, Barcelona

A brief introduction shows that fishery science has paid special attention to the problems posed by the exploitation of the living resources in the sea since at least the beginning of the 20<sup>th</sup> century. While the list of those working in the field is a long one, it was probably HJORT (1908) and PETERSEN (1892) that played the leading role of doing the first research work in this field. Initial efforts referred to the relationship between species and rough observations of the impact of fishing on the abundance of available resources. This situation arose out of the important fact that marine resources were seen to be inexhaustible. Although this assumption may appear to be strange and somewhat irrational, it was the one that somehow powered the dynamics of all fishing operations. BARANOV (1918) believed that the growth of fish was uninterruptedly exponential. Fish biomass would accordingly grow in the same way. A succession of research workers concerned themselves with these problems during the first half of the 20<sup>th</sup> century but almost all research work was limited to the study of the biological characteristics of the animals being exploited and, to a certain degree, the distribution of size and weight, and the inference from these data of the more or less favourable situation of the resource being exploited. The time distribution of data on size enabled growth as a consequence of the cyclical character of size to be detected and even measured in a very approximate way (PETERSEN 1892) and this was followed by studies that aimed at establishing age. At the same time, advances were being made in basic research like the structure of fish scales, where the existence of marked relationships with the annual cycle could be established fairly clearly, enabling not just age, which was of maximum interest, but also growth type to be established more exactly (LEA). Other important aspects like, for example, the reproductive process and the time of spawning were also researched in depth. While all of these aspects were important, there are two that are fundamental. The first

was the Lotka-Volterra model formula, the most successful attempt at modelling the relationship between prey and predator (LOTKA (1922)-VOLTERRA (1928)). Taking the exploitation of marine resources as just basically a relationship between prey (exploitable marine resources) and predator (in this case, fishing vessels), the formula was the first attempt to interpret and evaluate this relationship and draw conclusions from it. The next important step was the approach made by Russell (RUSSELL 1931) whereby a situation of equilibrium exists that is characterised by the following dynamic equation:

$$R + C = M + F$$

This simple expression enables the process of interaction between the available resource and fishing to be modelled. Firstly, it introduces the concept of time individuality, territory and action concerning the action of fishing in itself. Recruitment, R, is the process by which a new generation of the resource gets integrated into the part of the population that can be fished within the context of previously established conditions. Growth, C, gives the increase in the resource biomass during a certain unit of time. The natural mortality rate, M, corresponds to the natural process that leads to the reduction of the exploitable resource biomass during the same unit of time and space. Lastly, F represents the resource decrease brought about by the action of the predator (fisherman) or, in simple terms, is an index of the amount of fishing that occurs. There obviously needs to be a certain level of stability maintained in the RUSSELL formula for there to be a specific dynamic equilibrium between the productive capacity of the resource itself and the decrease attributed to the different types of mortality.

### Present-day routines

After this historical introduction, an explanation needs to be given of what is the signification of the Fishery Science. For many authors, it is merely the study and analysis of the group of possible strategies aimed at regulating the actions of man on renewable marine resources. For others, it in-

---

\* Author for correspondence: Carles Bas. Institut d'estudis Catalans. Secció de Ciències Biològiques. Carme, 47. 08001 Barcelona, Catalonia (Spain). Tel. 34 93 270 16 20. Fax: 34 93 270 11 80. Email: seccb@iec.es

cludes the modelling of marine populations that are subject to exploitation. The former is a biased vision that only takes strategies aimed at exploitation into account with a certain measure being given to the behaviour and in particular the reactions of the exploited population. What is basically interesting in the second case is that the population or exploited resource is considered within the context of the species itself, especially when this is affected by the action of fishing. The situation is undoubtedly much more complex and, at the same time, conceptually much simpler. In a clear predator-prey relationship, and fishing should be seen as such, one must bear in mind the entire ecological complexity of the system together with the socio-economic side that makes up the second part of the whole and which is closely related with a whole other reality. In short, this is a system situated within the ecological context and preyed on by another system that has mechanisms within its own dynamic structure (the socio-economic aspect) and both interact in fisheries. This could also be called ecobio-socioeconomics.

A large number of ecological studies developed by authors specialising in this field at the present time, are in reality demography studies and give a large number of numerical formulae that are not always clearly useful. With the other aspect, attention focuses on control and given that this poses numerous difficulties, mention should be made of the most recent viewpoint known as precautionary strategy (LLEONART 1998, between several authors).

Reliable authors (MARGALEF 1974) recognise that research into fishing has given a great boost to the development of certain aspects of ecology although there appear to be certain problems when considering its importance in the approaches made by ecological science. Many authors are now basically concerned with exploitation and conservation strategies like the aforementioned precautionary strategy or behaviour.

The process of ecological and socio-economic interaction that is characteristic of fisheries analysis needs to be mentioned here and particularly that this interaction takes place in two specific areas, i.e. as an exploitable resource and in the action of fishing.

Fishery science from a classical point of view developed out of the aforementioned considerations, and especially RUSSELL's approach, from the 1940s onwards. SCHAEFER 1954, RICKER 1954, BEVERTON-HOLT 1965, JONES 1961 and GULLAND 1971 were amongst the first to develop the basic elements for formulating production and analytical models that have been used for many years right up to the present day, and which have enabled two important objectives to be achieved. The first is the evaluation or quantification, albeit in a very rough and approximate way, of the exploitable biomass. The second is that they enable the most appropriate standards for maintaining the aforementioned equilibrium to be derived. The formulae presented by both SCHAEFER 1954 and BEVERTON and HOLT 1956 are sufficiently well known by researchers and it is not necessary to give detailed information here, although it is useful to point out the important advantages that they offer, together with the problems involved, which, to a large extent, have still not been overcome even today.

The first, which is particularly obvious in models of production, is simply that of dispensing with the factors that are involved in the process and putting the attention only on what is considered to be initial and end aspects (input and output), in other words the action of fishing, fishing effort and the catch obtained. Experience and practice have shown that without knowing what factors are involved in the process, it is impossible to move on from very rough information that in the best of cases is merely an approximation.

In the case of analytical models, while internal aspects like natural mortality, growth and, to a certain degree, recruitment are taken into account, the fact that the resource is not isolated but that it is intimately connected with the environment that surrounds it, whether this is a live one or a physical one, is not; in other words, the ecological aspect is left out. There was clearly a basic reason for this because it was impossible to handle an excessive number of parameters or excessively complicated formulae in the 1940s. On the other hand, an important factor that complicated the issue was that it is connected with density-dependent processes that can only be considered with models that were excessively complicated.

Nevertheless, these formulae have been good enough to control exploited populations. It must be born in mind here that these formulae require certain prior assumptions to be made, including the fact that the parameter for natural mortality,  $M$ , must be considered to be a stable value, which has been shown to be erroneous (VETTER 1988). Moreover, given the difficulty in assessing recruitment, it is not accounted for and its calculation is reduced to the unit of recruit in order to avoid the difficulty. Only a comparative index of abundance is thus obtained and this would need to be multiplied by an estimated factor that refers to recruitment as such.

Lastly, there is one other aspect that causes difficulty and this is that the factor of fishing mortality derives in fact from the action of fishing measured as fishing power and fishing effort. Without having to carry out a thorough analysis of these concepts, it is easy to understand the difficulty involved in correctly interpreting and measuring these parameters because there are many circumstances that are involved in making a correct estimation of them. Furthermore, it needs to be born in mind that while fishing mortality is possibly not only the most important parameter in the dynamic equilibrium equation expressed by RUSSELL, it is also the only one that can be controlled by man in his attempts to establish or maintain the necessary equilibrium so that the resource and fishery undertakings can be maintained in the right proportions. Lastly, between fishing itself and the catch connected with fishing mortality,  $F$ , a certain proportion is expressed by the catchability factor,  $q$ . In most cases, this factor is considered to be constant although experience has shown that this is not so and that in fact it varies constantly due to reasons that have to do with ecological and ethological circumstances and even the fishing strategy. In this respect, it must be born in mind that while they express subtle distinctions, the catchability concept, availability and accessibility all modify the aforementioned relationship. Given that, according to the basic concepts governing the usual

formulations, space is limited, that distribution is random, and the assumption that the situation is in equilibrium, which are circumstances that rarely occur, the aforementioned parameters can be considered as being constant in these conditions without this leading to any serious error in the models in approximate terms.

Several unimportant strategic variations followed although the conceptual structure of the models remained unchanged. An important yet non-significant improvement was introduced by POPE (1972) in the concept of generations or cohorts, more specifically known as the virtual population analysis. This innovation basically involves analysing each generation that makes up a population, which provides a more detailed analysis of the population structure. If an individualised analysis can be made of each of the different generations that normally make up an exploited population (the number will depend on the average age of the population), not only will a more detailed picture be obtained but it will also be possible to detect the impact that different circumstances have in each case, which is especially important at the time when recruitment takes place. The method followed by POPE to analyse each cohort enables the calculation of abundance to be made each year from the time when the extinction of the generation under study occurs in practice. By backtracking, a detailed-enough calculation can be made of the number of recruits that started the generation being examined. As well as providing an analysis of the exploited population that is more correct, the method enables variations from one generation to the next to be detected (as has just been explained) and although it is not capable of examining the causes, it clearly shows their existence and stimulates new approaches for considering this situation.

Another important innovation is multi-specific analysis, which is particularly interesting when there are ecological interrelationships of a generally trophic nature between different species being exploited. There are numerous examples although the classic one refers to the exploitation of krill, whales and seals. Massive fishery undertakings that seriously reduce krill biomass and that endanger the stability of the whale and seal populations that fundamentally feed on the krill can be accounted for with this analysis. On the contrary, the indiscriminate catch of cetaceans or phocidae may give rise to an unbalanced increase in krill. These types of models are more complex than the previous ones because they have to take account of the interrelationships that exist between the different exploited species. This case needs to be distinguished from the simple simultaneous exploitation of various species, particularly when there is a priority one, for example, the case of cod, hake, etc. where a specific species is being fished and the others, although they are not rejected, are at least not taken account of with regard to the control of fishing. The problem becomes more important when there are various species that are normally exploited and which are all important for fishing, and amongst which there is no mutual interference, at least in terms of the trophic relationships but where there are marked differences concerning the different parameters characterising the analysis

of the populations (growth, natural mortality, etc.). Regulation is generally speaking very complicated because it is difficult to make the minimum catch sizes coincide and consequently recommended meshes and other preventative measures. This situation is very evident in certain fisheries in coastal areas and particularly those situated in the Mediterranean Sea.

These points of view have been fundamental in the research of fishing in exploited areas over a period of years although it is becoming increasingly obvious that it is very difficult to understand and accordingly model processes that cannot be explained just from the point of view of their internal dynamics in view of the fact that these are totally connected with the processes that surround and condition them. The first aspects considered are related with the possibility of somehow measuring the trophic relationships between the resource being exploited by fishing and the available food, a predator-prey relationship that is reflected in a way by the LOTKA-VOLTERRA formula mentioned above. This situation has been gone over in numerous journals, congresses and especially in the model presented by ANDERSON-URSIN (1977). The characteristic of the model is that it analyses the importance of the abundance of food in the stability of the exploited population. There are numerous examples that show that the greater availability of food gets translated into an increase in growth of the specimens that make up the exploited populations and accordingly in an increase in fishing. Firstly, the easier the model the better and it must be said that a characteristic of the model, which is not so highly considered these days, is its complexity. In the case of the biological processes and even more so with ecological type, this question is particularly important. A second aspect has to do with variations in available food caused by fluctuations in the environment. This circumstance is especially important when the food consists of higher links in the trophic chain (phytoplankton and zooplankton) that are highly sensitive to variations in environmental conditions. It is well known that in proportion to the distance of food source at the beginning of the chain, the oscillations are gentler and the environmental impact is indirect. It seems that the true line to follow when integrating the model of population dynamics should be by setting some particular parameter that expresses in overall terms not just the quantity or quality of the food but also the energy absorbed. It is possible that this may simplify the structure of the model and make it easier to apply. This new approach would obviously introduce some basic parameters in this analysis that are connected with the environment (temperature, salinity, nutrients, etc.) although this would undoubtedly occur later on in the matter being given consideration.

### Exposition of the classic models

Between the more used and classic models here are considered the following:

General yield after the Beverton-Holt formula

$$Y_{\infty} = FR_e - M_p W_{\infty} \sum_{n=0}^{\infty} \frac{\Omega_n e^{-nK(t_p-t_0)}}{F + M + nK}$$

If only the yield per recruit is considered ( $Y_{\infty}/R$ ), the reformulation is:

$$Y_{\infty}/R = F - M_p W_{\infty} \sum_{n=0}^{\infty} \frac{\Omega_n e^{-nK(t_p-t_0)}}{F + M + nK}$$

– Schaefer's formula

$$Y = aEe^{-bE}$$

$$\frac{Y}{E} = ae^{-bE}$$

( $E$  = fishing effort)  
– Fox's formula

$$Y = aEe^{-bE}$$

$$\frac{Y}{E} = ae^{-bE}$$

**Parameters**

Up to this point, an analysis has been made of the models used yet it is worthwhile mentioning how the parameters involved in the different models are measured and interpreted. Variations have occurred in the way that the recruitment process parameter has been calculated and it is the models by RICKER (1954) (see Fig. 1), and BEVERTON and HOLT (1966) that in principle stand out.

The main problem however arises from the fact that there is no clear relationship in practice between what can be considered and the lack of experimental support. In this aspect, mention must be made of the ALLEE (1949) phenomenon in connection with the inherent difficulties of successful fecundation when the reproducer density is excessively low, which

can diminish the encounter rate between the male and female components of the reproductive process. This phenomenon not only affects the success of reproduction, a process situated between reproductive stock and hatching, but also explains why excessively degraded stocks find it impossible to recover current expression:

$$R = \frac{1}{\alpha} \left( 1 - \frac{\beta}{\gamma} \right)$$

$\alpha$  and  $\beta$  are density-dependent parameters connected with the larval mortality that varies according to the species and the time between  $t_0$  (hatching) and  $t_p$  (recruitment).  $R$  tends to have an asymptotic value when  $E$  (number of fish eggs) tends to be  $\infty$ .  $E_{\infty} = 1/\alpha$  are curve of the slope is the same as  $\beta$ .

$$R = \frac{1}{\alpha + \beta E}$$

Different phenomena were understood from these results such as existing mortality, for example, although the problem is twofold; on the one hand, knowing when the critical moments are when maximum natural mortality occurs and, on the other, knowing what processes are actually taking place. A very simple fact (comments SHARP) is especially encouraging in this respect. If it can be made clear that natural mortality in the pre-recruitment period is very high and the objective of fisheries control is merely to ensure a minimum number of reproducers, it would be much more efficient to reduce mortality prior to recruitment, even by just a little, than all of the measures that are being practised at the present time. As far as what is known at the present time, certain critical moments occur in this mortality, which needs to be separated into mortality  $M'$  connected with density and mortality  $M''$  connected with processes that are intrinsic. Disregarding the moment of fecundation, the highest mortality occurs at the moment when the yolk sack is exhausted and the larva begins to feed in a more or less active way. Both the abundance of food and the fact that this food is of the appropriate quality to serve as food, in particular concerning the

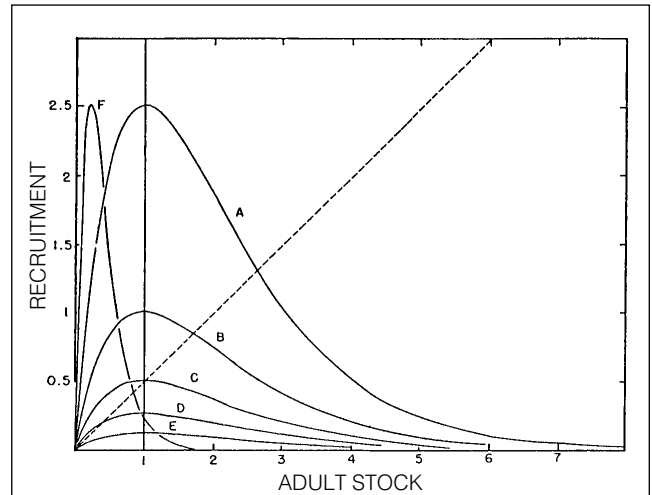
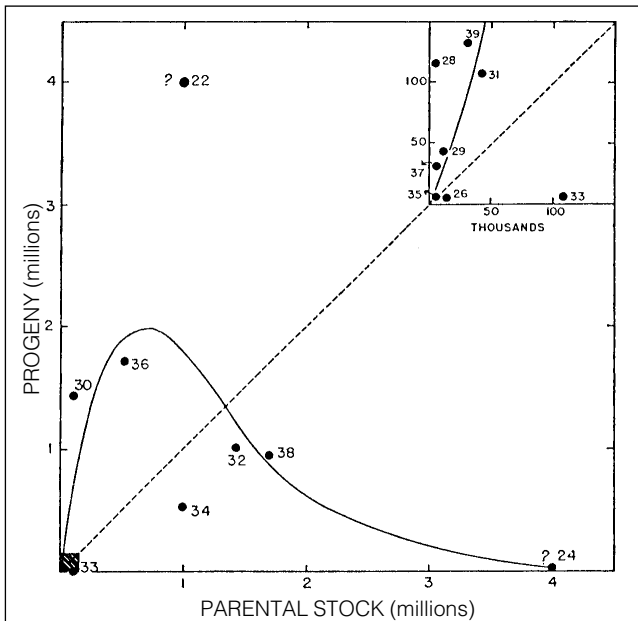

Figure1. Relation between the reproducing stock and the progeny. a) scheme according to Ricker; b) other recruitment schemes depending on the perturbing factors (Ricker).

size in relationship to the diameter of the larva's mouth, are important in this circumstance. This study led to the analysis of larval muscular structure, which clearly indicates any possible states of food shortage, along with the analysis of the stomach content of young fry. The impact of the environment on the initial phases of development of the larva, especially at times of maximum lability, can also be established or, even better, checked.

Growth is another parameter that is fundamental and has been intensively investigated as a result, both from the physiological point of view in terms of measurement, and as practical interpretation when used in modelling. In this respect, it must be pointed out that things have moved on from the descriptive phase of growth based on the comparison of size over time to a vision of the physiology of growth itself from von Bertalanffy's formula that is based on comparisons between catabolism and anabolism. From here, and by using different strategies, a useful formula can be obtained that enables a large quantity of data to be handled. This is the well-known von Bertalanffy formula although the approach has more to do with the ideas of Beverton-Holt, which developed the basic ideas proposed by von Bertalanffy. Using von Bertalanffy's ideas, and by assuming certain simplifications, the proposed formula is as follows:

$$L_t = L_{\infty}(1 - e^{-K(t-t_0)})$$

which gives a numerical representation of growth. It is important to point out the meaning of  $L_t$  which is the maximum asymptotic value (and which the species under consideration tends towards). The specific parameter is  $K$  connected with the previous one through metabolic activity. In this case, there is a solid scientific basis although the numerical transformations that are necessary for handling a large quantity of data introduce a wide margin of uncertainty. Lastly, to has little biological meaning given the experimental verification.

It is clear that the key problem in the study of growth is determination the age. Things here move on from the calculation of age groups (PETERSEN 1892), based on the fact that, in general terms, the reproduction period is limited in time and gets repeated periodically (annually) so that the modes observed in the distribution of size correspond with the different age classes, and growth after the first age group or class sampled. The numerous difficulties that occur with this system have been improved by following different techniques, amongst which the one put forward by BATTACHARIA (1967) is possibly the most effective. Other methods are based in similar situations, like the regularity of growth cycles that get recorded in certain types of osseous structure. Fish scales were initially used for they contain a series of markings that correspond to each year of life. Scales were then replaced by otoliths because all species have otoliths whereas some fish do not have scales. Moreover, growth rings in these structures that correspond to periods of intense and slow growth (annual cycles) as well as daily and even 12-hourly growth can be detected, together with the different special features that have

occurred in the life of the fish (changes in habitat, stress, etc.). This enables a more precise monitoring of the growth process to be made through better estimates of age. In-depth study of the structure of otoliths has enabled not only a more accurate study of the process to be made but also, and what is even more important, the characteristic and individual features of the life of each individual to be reformulated. The application of new technologies enables the time and intensity of different events in the fish's life to be ascertained. Nevertheless, the formula based on von Bertalanffy or others like GOMPertz's formula that are more or less useful, do not completely conform to reality, largely on account of certain phenomena connected with differential or allometric growth. Certain variations in the form mean that the size/weight relationships closely connected with behaviour (index of condition) vary over time and, therefore, to correctly assess these data, variations in the allometric relationships would need to be taken into account. Furthermore, the fact that the different variations in these relationships have a close relationship with the ecological, physiological and ethological changes that take place during the life of the fish (migrations, reproductive period, etc.) would appear to be confirmed. In any case, changes in the type of growth are fundamentally important not just in the way that they affect the growth of each individual but also, and to a much more important degree, the variation affecting the biomass as a whole. It is accepted that these variations at the present time happen as a response to environmental variations that, according to circumstances, affect each of the generations that make up the population. In the overall context of growth, the concept of *form* is very important and not just in itself because it is the plastic expression of the equilibrium between the internal system and the ecological system that encompasses it.

Two parameters, that could be grouped together as one (mortality), need to be considered in the general formula. From the practical point of view, however, it is useful to separate the part due to natural causes from that caused by man acting as a predatory element. Natural mortality, the first aspect, is a broad term that takes account of all of the facets that cause a decrease in the biomass, irrespective of man. This parameter has usually been accounted for in formulae as a fixed, stable parameter that is very difficult to assess, while it gives approximations that are simple and roughly approximate. It has been suspected for some time, however, that this parameter is not only unstable but that it undergoes wide variations in time. This variability has been demonstrated according to the estimations of VETTER (1988) who checked this question. The fact that this variation is important during the period prior to recruitment, particularly during the initial stages of life, was already well known although the present confirmation refers to the post-recruitment period and contravenes the idea of natural mortality being a constant parameter, which has normally been accepted. This is highly important because the value of  $M$  has a direct impact on the existing biomass and in consequence the conservation patterns will be of one sort or another ac-

ording to the value of  $M$  and even more so if this parameter varies throughout time in relationship with the variations in environmental and ecological characteristics. It is well known that few fish are eliminated as a result of natural death or illness. A large part of the value of  $M$  will thus be caused by predation by other species. Calculating this runs up against serious difficulties and the tables drawn up by PAULY (1987) in relation to environmental temperature present serious difficulties connected, on the one hand, with the biological characteristics of each species and, on the other, with the impact of the environment on growth, an aspect that has already been mentioned above.

The other component is fishing mortality. This parameter is important because it is the only one that can be subjected to control in the initial equation and it presents a lot of problems as regards correct interpretation. In fact, the catch is the result of fishing mortality and it depends directly on what is known as the fishing effort, i.e. it is the result of the application of a certain fishing power during a certain period of time to the stock being exploited. As such, it would appear that there is no particular problem but questions arise when numerous difficulties that may occur are observed when fishing power is measured, which is influenced by a wide number of variables. An example is the application of the concept of time, which is not always easy to interpret because measurement depends of the fishing techniques and how they are used. Another factor that is highly important derives from the apparent proportionality established between the catch and the fishing effort. This proportionality, signified by  $q$ , is also considered to be a constant factor known as the catchability constant. The differences between the concepts of catchability, availability and accessibility certainly need to be clarified although at all events it is obvious that while in some fishery undertakings  $q$  can be considered to be constant, at least for long periods of time, this is not so in many other fishery undertakings especially where artisanal methods are used, like most coastal fisheries and more specifically in the Mediterranean. The value of  $q$  constantly and rapidly changes from one period to another and this makes it difficult to establish a correct relationship. The appropriate analysis of the behaviour of  $q$  compels not just a detailed, in-depth study of the ecological characteristics to be made but also and particularly the behaviour of the species and especially its responses to different fishing actions. This type of research in the study of behaviour is lacking.

In general, knowledge of the aforementioned parameters is necessary in order to prepare the models used to interpret the dynamic processes and the more correct this knowledge is, the better the model will be, despite any inherent limitations. In this respect, models of production (the relationship between catch and effort) will clearly be easier to apply than any kind of analytical model. Furthermore, in terms of the relationship between the catch and effort (CPUE – catch per unit of effort), the result gives an index that measures abundance. Despite the serious imperfections that are involved, this model is extensively used for obtaining information on

the situation of exploited populations, along with the impact of fishing at the same time.

In most exploited populations, however, it is not possible to obtain the necessary data and even less so in the case of statistical series that offer a minimum degree of reliability. In these cases, PAULY (1979) used a strategy that enables the aforementioned parameters to be estimated from a minimum quantity of information practically consisting of the demographic distribution of the catches. This system enables information to be obtained on age, growth, natural mortality and levels of selectivity that, together with certain data on catches and effort, give analytical models that are more credible than production models.

BAS et al (1955) propose a graphic expression combining several basic data-information to present situation of a particular stock related his exploitation level (see Fig. 2).

One of the problems posed by models, together with all of the theory normally followed in the study of populations subjected to exploitation, is that they refer to very important fishers that are characterised by a certain unidirectional pressure around a certain species such as cod in the North Atlantic, hake to the south of Ireland, etc. In the majority of cases, however, the real situation of the populations being exploited is quite different in that small communities where the majority of species are of commercial interest are being fished. This makes it enormously difficult to interpret the fishing effort parameter because this parameter is directly linked with the species considered to be the priority objective of the fishery operation. In certain circumstances, fishing effort can certainly be applied to the whole of the multi-specific exploited population although a very detailed analysis would really be necessary because the effort generally has a specific direction. That does not mean, however, that if the preferred species does not appear, generally as a result of a low  $q$  value (catchability), then the fishing effort can be put on other species or indirectly on all of the community exploited as a whole. Another very important aspect, which is especially apparent in fishery operations using artisanal methods near the coast, has to do with the fact that a large part of the catches consist of specimens that are smaller than what is considered the natural recruitment size. This causes an important distortion in the application of models because a certain level of recruits is accounted for although a very high percentage of catches are clearly made up of specimens that in principle should not be fished. Two highly important examples are hake and red mullet in Mediterranean fisheries. Both species have a high reproductive capability so in normal or favourable conditions, from the environmental point of view, there is quite literally an explosion of young fry that are smaller than recruitment size. Given that a large amount of fishing involves these small specimens, model-building receives a strong impact from the structure of fishing operations that remove a large part of the exploitable biomass from what can potentially be fished. So, on the one hand, the recruitment parameter does not correspond with the real situation and, on the other, mortality per recruit is highly increased, which leads to distortions in the calculations. CADDY (1989) has

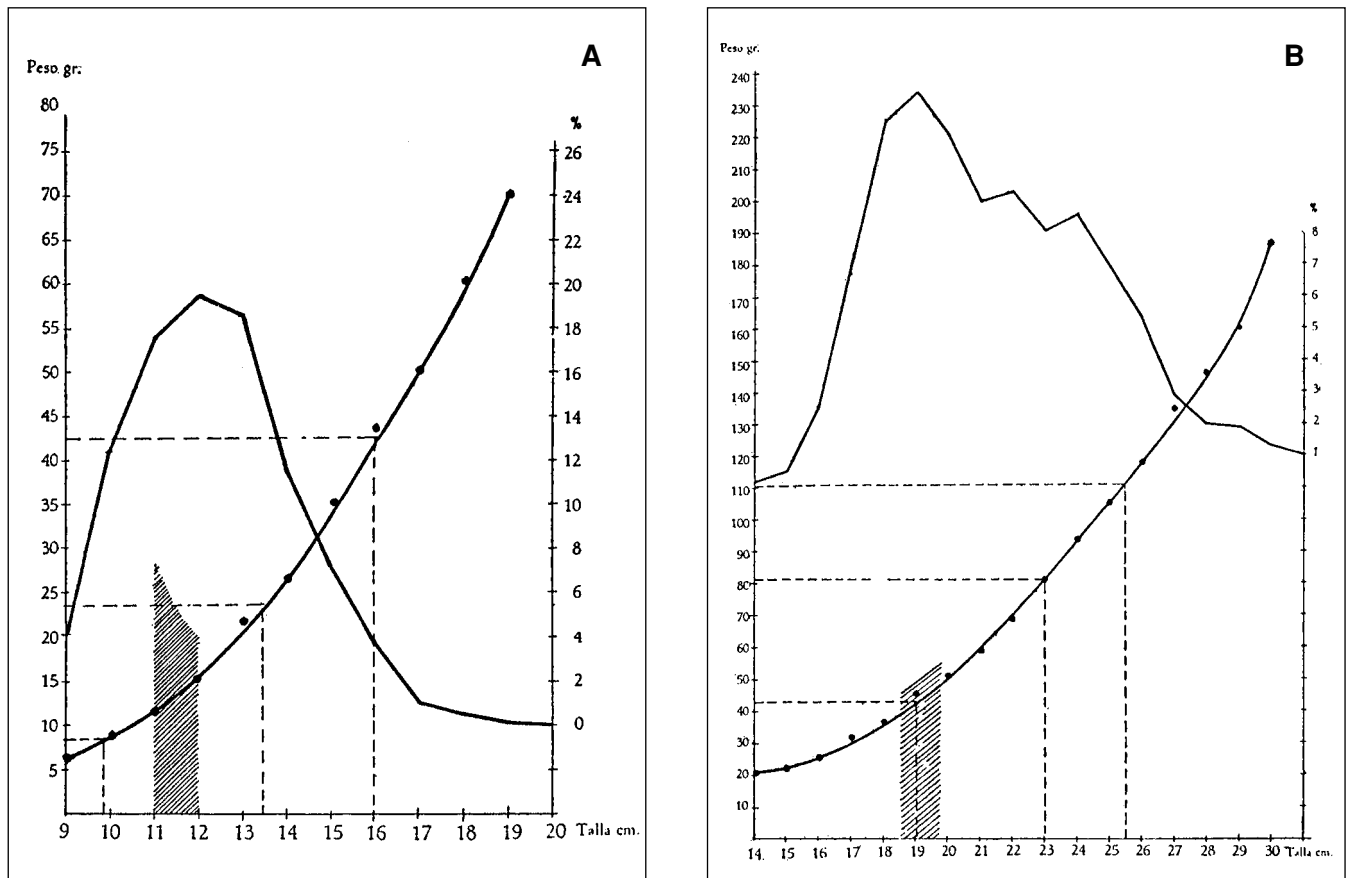

Figure 2.. Graph relating the size distribution, the relation by sizes, age-size and size of the first reproduction (Bas *et al.*). a) poor-cod; b) blue whiting.

drawn attention to this highly important aspect, which increases the need for new approaches to modelling.

Furthermore, if the trophic relationships factor was introduced at some time as an important element in the modelling of the dynamics of exploited populations and at the same time as an expression of the relationships between the exploited resource and the ecological environment (other living elements) the majority being considered as food of the resource, it becomes increasingly obvious that a more close relationship is absolutely necessary between the exploited resource and the medium in the broadest sense of the word. Establishing relationships with the other living beings is no longer enough because the environmental impact (different masses of water, ocean currents, the effect of the wind) needs to be established, and in the most appropriate way possible, because this is a basic element in primary production and consequently has an influence on overall productivity. From the movement of different currents, the location of marine fronts and whether these are the talus or the result of friction between different masses of water, fingers with a high headwater productivity, the presence of cyclical eddies that cause the upwelling of deep water rich in nutrients, inflows of fresh water, coastal lagoons and reefs and, in a broader sense, the geomorphology of the continental shelf and talus, all of these elements have to be taken into account when formulating an understanding of the marine ecology where a resource, whether it is a unispecific or multispecific one, is located. This is the only way to establish a

position that is minimally solid enough for it to be tested as a valid model.

### Current approaches: tensions and emerging aspects

Despite the important advance made by the contributions of the aforementioned authors, the biggest difficulties arise from the fact that it is becoming increasingly obvious that there is no clear explanation of the understanding of the dynamics of exploited resources, and the different attempts that have been made have not come up with solutions that are sufficiently correct. The problems come from both a lack of perspective concerning the relationship between the resource exploited and the entourn in which it is situated and, as a consequence of all of this, the difficulty in controlling or managing this in order to achieve a sustainable situation. One of the biggest difficulties derives from the fact that traditional models assume situations of equilibrium whereas experience clearly shows that bioecological systems normally operate in situations that are not in equilibrium or that are extreme. One of the problems is due to the fact that it is not possible to establish a stock's potential if it is not subjected to over-exploitation; the problem is as to find an adequate way of reducing the effort. Given the situation of uncertainty that exists, a choice must be made between two different dynamics. It is therefore a situation that is closely connected

with the action of fishing and not directly with what is generally known as fishing biology, an expression that does not really make much sense.

There are two aspects that are important. The first is that the maximum trophic efficiency, or the adequate conversion of food into matter resource, happens relatively early on and can serve as a reference for establishing the minimum size for fishing (selectivity), while the second is that maximum economic yield is established before the theoretical maximum sustainable yield. Just as behaviour is important in the study of the resource, so the analysis of its behaviour is fundamental in the study of the economic impact. In this respect, models are based on an idea of stock defined as being a structure that maintains characteristic levels of growth, reproduction and natural mortality and that is also subjected to a set strategy of fishing. This structure can be considered to be like a super-organism that has its own processes of selection and evolution. In any case, these structures undergo certain disturbances that, instead of returning to a stable equilibrium, attain situations that are cyclical. The relationship with its surroundings (environment, other species, economy, etc.) is what causes the variations and, according to their nature, the type of variation. The study of long historical series, especially those that refer to stocks/populations situated in areas of high productivity and large potential biomass, shows the existence of large, cyclical oscillations.

Up to this point, the variations influenced by what can be considered to be the internal dynamics of the resource have been referred to, although the importance of the dynamics of the fishing fleet (fishing power and fishing effort) also needs to be taken into consideration for it is closely linked. Very little analysis has been made of these parameters despite the fact that their influence is highly important and even essential for the correct management of the exploitation of marine resources. There is a need for greater attention being paid to the correct understanding of how they (HILBRON – WALTERS 1992), operate because his accurate modelling facilitates the correct and global model of the fishery. In this respect, it is important to gain not just a greater understanding but also to make a in-depth study of the resource's most sensitive aspects, such as pre-recruit and reproducers. Insisting yet again on the importance of behaviour, spatial distribution is highly important and the existence of concentrations, due to either environmental (hydrographic fronts) or trophic (abundance of food) causes, can give rise to erroneous estimations of abundance as a consequence of the false interpretation of the CPUE in connection with variations in vulnerability. These situations can affect different parameters, especially recruitment and in a direct way the relationship between the parental stock of the reproducer and the number of recruits. From another point of view, the need for long series of data presents very important problems because it is very difficult to obtain homogeneous sets. In this respect, a more in-depth use of Bayes theorem may enable series that are somewhat heterogeneous to be used without overlooking the fact that there is clearly a certain influence in all of these cases between the different values/data of a se-

ries. In this respect, the possibilities offered by the fuzzy set theory should also not be overlooked. Finally, it should be born in mind that, in many cases, more information appears in the observed deviations than in the whole of the sum of data itself. In this aspect, being able to pay special attention to critical moments (recruitment, reproduction, migrations, etc.) through the detection of deviations can provide correct and useful information in a relatively easily way in terms of the gathering of information. Attempts can be made to obtain more correct information so that the parameters and, more importantly, the deviations that occur can be assessed. On this same point, historical series with time deviations are very interesting although a careful biological analysis is necessary in order to explain the process in a comprehensive way. Situations of this type occur when comparisons of series of abundance between reproducers and recruits are made. These situations give rise to cyclical or half-cycle relationships that are highly interesting and are commented on further on.

Following the analysis of the parameters, models that give an estimation of the biomass are necessary to provide instruments so that appropriate strategies for managing fishery operations can be proposed. As has already been pointed out, the models of production are too rough because the data are not reliable enough and the estimation of the maximum sustainable yield (MSY) is a low efficiency contribution. Amongst other things, it will never be possible to know the reaction of a stock to fishing without fishing ever having been done there before. This model seeks to estimate the abundance although the CPUE is not always strictly proportional to it. Methods of acoustic assessment, despite all of the errors that they may incur, can provide direct estimations of biomass.

A very important question in reference to fishery operations is the system's ability to regenerate itself. Some resources have a high ability to recover, especially species that are closely linked with the initial links of the trophic chain or directly influenced by environmental (oceanographic or geomorphological) parameters that directly influence the processes of recruitment or changes in natural mortality. These types of situation, which are very frequent, have been given little consideration although they strongly distort the perspectives because they give rise to variations in abundance, especially in the youngest age classes. This recovery ability does not correspond to cyclical variations but appears to be more the result of variations in the system's basic production capacity together with special characteristics of the exploited resource.

An important aspect to take into account is the recovery ability of certain types of marine resources. Phenomena like population collapses need to be more intensively studied because, on the one hand, the influence of the ALLEE effect (ALLEE 1949) can interfere with possible recovery and, on the other, one also needs to take into account that economic collapse (minimum economic profitability) occurs before the real extinction of the resource. This gives the resource an opportunity to recover when the ecological circumstances



are favourable enough although this does depend on the species that is depleted.

It is important to pay maximum attention to the behaviour of the fishing fleet and in particular to its fishing power. Whereas the behaviour of the ecological predator has been studied, little attention has been paid in research to the significance of this specific predator (fishing power), and it may be these more effectively. In the future, it may be possible to more effectively assess technological interactions that are in a way just as important as ecological ones.

Whenever maximum catch quantities, commonly known as TAC (total allowable catch), need to be indicated, a matter that seriously need to be considered is of ensuring the minimum quantity of females to provide a reasonable number of hatches/recruits. In this respect, one should bear in mind the questions concerning reproductive behaviour, the ALLEE phenomenon and the high mortality that is typical during pre-recruitment. Each species and situation deserves special attention without overlooking the gender distribution that is not always the same. SARDA and collaborators have detected interesting differences in some species (*Aristeus antennatus*), and this also occurs between different sizes of the same species. All of these circumstances make fishery operations (restrictions in fishing strategies, fishing techniques, different types of limitations, fishing quotas, minimum sizes, etc.) highly complex and uncertain and a highly conscientious analysis therefore needs to be made.

«Pulses» occur in the majority of fishery exploitations that are sometimes due to good ecological conditions that act as a stimulus for the economy and on other occasions to economic stimuli that force a higher rate of fishing exploitation, even in cases where the resource is being overexploited. A very clear example of this has occurred in the exploitation of the majority of the fishing resources in the Mediterranean. These situations are difficult to control and are in general heading towards a point where it will be difficult for them to recover. A reasonable decrease in the economic stimulus helps to improve the situation. Yet again, the application of so-called «precautionary conduct», fundamentally to the socio-economic aspect, gives very positive results.

Up to this point, special attention has been paid to the aspects related with the action of fishing vessels on the resource and the different aspects and problems posed by research in this field. This brings us to the point of considering the situations that have to do more directly with the strictly ecological side of the problem. It is essential to establish a correct relationship between the dynamics of the exploited resource, whether this is one or various species, and its ecological relations. The need is truly widely recognised although important technical problems arise here. The approach expounded by PALOVINA (1984) will be particularly taken into account here, and the contributions made to this by CHRISTENSEN-PAULY (1992, 1993 and 1995) and JARRE-TEICHMANN (1991), which which have given rise to the ECOPATH models that are based on the ideas expounded by ODUM (1969). The authors are convinced that, in order to correctly assess a certain resource, it is necessary to not

only assess/estimate its biomass along with the parameters that characterise its dynamics but also to establish the relationships with its surroundings that are determined by a series of fluxes (Fig.3) between the different components. These models are based on trophic interactions. The possibility of maintaining a certain level of ecological sustainability in a fishery can thus be assessed. To sum up, a series of compartments in the construction of a flow model are taken into account. It is a question of measuring the energy balance of each component, expressed according to consumption:

consumption = production + respiration + unassimilated food

With regard to consumption, reference can clearly be made to the internal elements of the system itself, along with external contributions. As for production, reference is made to the fraction consumed by predators, along with the fraction exported out of the system and the part that turns into «detritus», a fraction that has become important in the dynamics of the system from the overall point of view. Production, referred to as the element  $i$ , is the result of total predation on  $i$  plus the loss of  $i$  not due to predation plus the catches made of  $i$  and, lastly, other  $i$  and non-specific losses. The production corresponding to  $i$  can also be expressed as a function of  $B_i - P/B_i$ . Loss due to predation is:

$$\sum_j \left( B_j \cdot \frac{Q_j}{B_j} \cdot DC_{ji} \right)$$

Other losses not caused by predation

$$(1 - EE_i) - B_i + \frac{P}{B_i}$$

In this case, a situation of equilibrium is expressed by the following equation

$$B_i \cdot \frac{P}{B_i} \cdot EE_i - \sum_j \left( B_j \cdot \frac{Q_j}{B_j} \cdot DC_{ji} \right) - E_{xi} = 0$$

where  $i$  = a component;  $j$  = a predator of  $i$ ;  $B_i$  = biomass of  $i$ ;  $P/B_i$  = production of  $i$  per unit of biomass (in case there is stability, this will correspond to total mortality);  $Q_j/B_j$  = consumption of a component per unit of biomass;  $DC_{ji}$  = the average fraction of  $i$  in the diet of the predator  $j$  expressed in units of mass;  $EE_i$  = ecotrophic efficiency of  $i$  (part of the total production consumed by the predators or exported out of the system);  $E_{xi}$  = system exportation and exportation out of the system (emigration or fishing). In some cases, there is frequently a lack of information in some of the parameters for some  $i$  being considered. The model will be correct and balanced when information is available for all of its components. In this respect, it is highly important to know what the strategies of behaviour are of the different species that make up the system. Some ecological models (JORGENSEN 1994) provide an understanding of the relationships between the components, as well as a flow analysis. In this sense, an assessment of the cost that fishing represents for

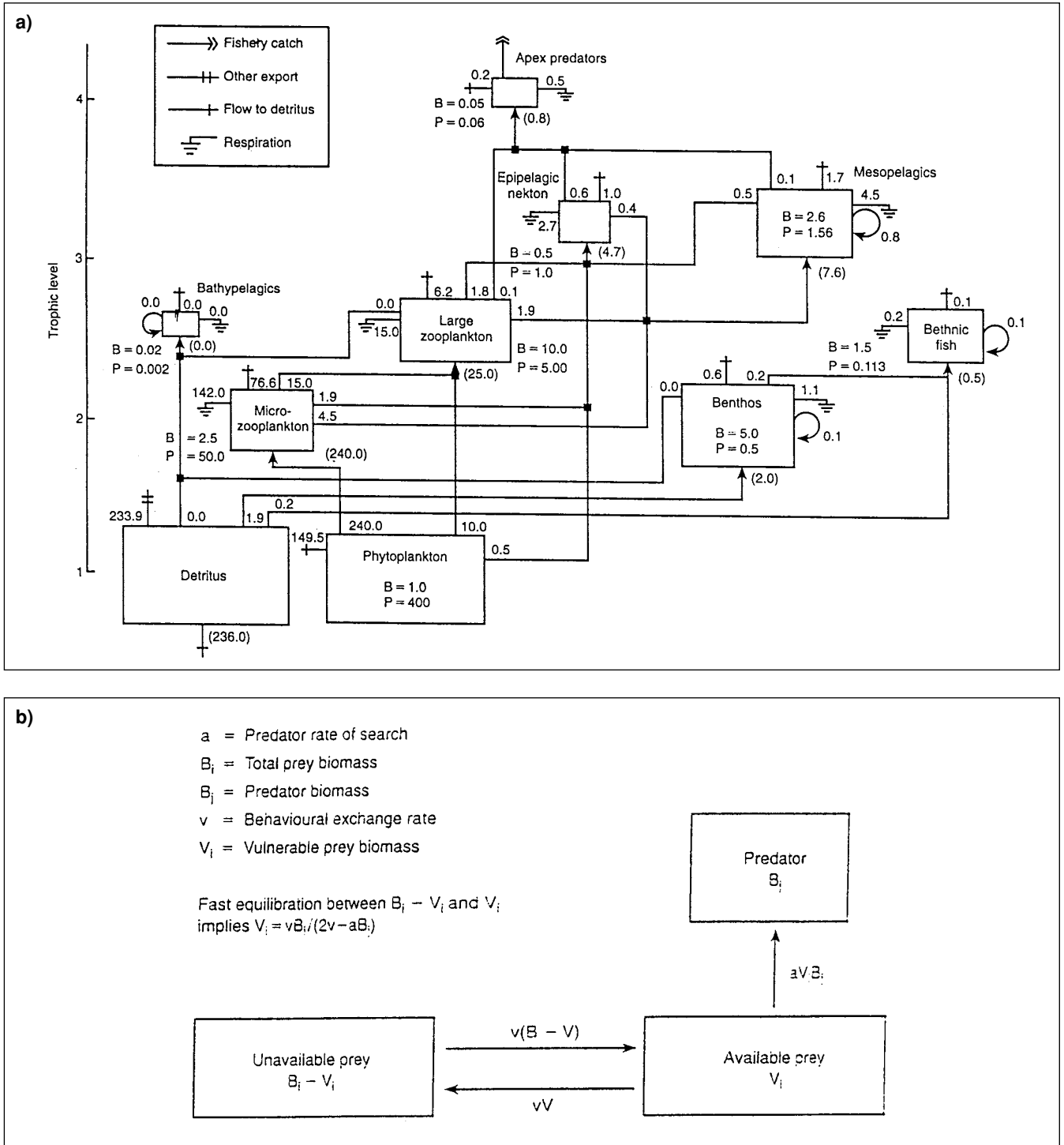

Figure 3. ECOPATH model (from PAULY-CHRISTENSEN). a) the size of the boxes are +/- proportional to the logarithm of biomass. Arrows documents of interrelations; b) ECOSIM model (WALTER *et al*).

the whole of the ecosystem could be tested. If this could be appropriately developed, it would be of great importance for prospective approaches.

Some authors in their recent works (CHRISTENSEN-PAULY 1992) also refer to ODUM (1969). They take account of twelve measurable characteristics, out of the total of twenty-four characteristics pointed out by the author, for detecting the state of evolution of an ecosystem. The system of equations indicated above is used to obtain a balance between masses. The largest part of production in marine

ecosystems is used for predation or for fishing and very few animals, especially in the more advanced sections, die of old age, natural mortality or as a result of illness. Nevertheless, one must bear in mind some cases where natural or spurious causes cause mortality on a massive scale (red tides) although these are always very point-specific. The fundamental element for understanding the dynamics of the ecosystem is to calculate the interrelationships and relationships with the adjacent strategies. The dynamics of this are set within a certain context that is defined by the system's

the carrying capacity. Any variations or changes that may occur in the system's overall carrying capacity can bring about very important oscillations in its internal dynamics. This could be considered to be the framework or context of the setting, which delimits the real possibilities of the dynamics. Variations in its components, where the action of fishing in almost all cases has a very important significance, will always adapt to the system's carrying capacity. Ecosystems that have their dynamic structure (mutual relationships) degraded by the heavy pressure of exploitation (fishing) are always a long way from their maximum carrying capacity. Within the context of the different levels of development in the dynamic relationships in the ecosystem, fishing always acts in the middle and/or end levels and the impact that it has will be related with this situation. The exploitation of small or medium-sized pelagic species thus has a different impact on the overall strategy to that of species situated in the more evolved sections that are more likely to have achieved a higher level of equilibrium in the system. On the surface levels in the sea, the group included in the large migrators (end links) have the possibility of resisting changes in the environment by making use of their great mobility and ability to shift location. The study of the stocks of striped tuna (*Katsuwonus pelamis*) in the North Atlantic is a good example.

Furthermore, the demersal species, which make up the benthos, use another type of overall strategy and at the same time have a lower resistance to disturbance such as that caused by fishing. Nevertheless, greater attention needs to be paid to certain aspects concerning the strategy of benthic systems. Firstly, a lot of attention needs to be paid to the significance of detritus, especially that caused by the population (plankton and others) in the surface layers of the sea. The possibilities of intermediate elements (bacteria, filterers, detritivores, etc.) using the detritus enables supplementary food to reach the resources that live near the bottom. Secondly, consideration needs to be given to the important role played by the living beings that are capable of making significant nocturnal vertical migrations (Euphausia, mictofidos, etc.) and of transporting material and energy from the surface layers to the bottom with hardly any loss. Predators of these at the bottom have a lot more biomass and nutritional energy. Lastly, another important aspect is related with the vertical migratory ability of certain benthic fish, for example gadids and merluccius, that are capable at night of reaching depths that are a long way from the bottom which increases the possibilities of more food. To sum up, more information is needed on a whole series of strategies that needs to be considered in order to correctly interpret all different types of ecological relationship.

Amongst all of the models that have been mentioned above, a variant considered recently and that is more effective is the ECOSIM model (WALTERS et al, 1997), which takes account of the conduct of prey, its spatial distribution and availability in relation to the predator. There is thus a progression from the simple balance of mass that is typical of the ECOPATH model to a new, more dynamic one. The primary

production of the overall system can be considered to be constant although this is surely incorrect, and parallel to this it could be represented by the carrying capacity that operates, as has already been mentioned, like a framework for the whole. Within the framework of the system, one aspect that needs to be taken into account and that is certainly not very frequent is gastric saturation. Specific studies of this are necessary. The encounter mechanisms between prey and predator are amongst the many aspects that need to be considered between prey and predator because, far from what might appear to be so, this does not happen by chance. All of this is closely related with availability ( $V_{ij}$ ) that, as has already been mentioned, is very changeable and does so very rapidly. The ECOSIM model contributes to a highly interesting aspect, i.e. the role of detritus, which is seen to be increasingly important. The model also presents a series of problems in that species with low levels of fecundity are incapable of transmitting certain improvements that follow on from an improved abundance of food to the system. In other cases, increases in the value of  $F$  leads to a decrease in natural mortality. This, together with other problems related with the stability of  $M$ , deserves more attention. In very complex models that have a lot of compartments, small changes can give rise to large variations, especially in the  $V_{ij}$  parameter. Tropical systems are a good example of this. Lastly, this model can be of use in obtaining useful results, especially of the relationships that are considered to be determinant in the system as a whole; while great quantity of information is not always more useful, what is necessary is for the information to be fundamental and determinant.

The understanding and research of an adequate strategy for managing a resource and the in-depth study of the ecological relationships that the exploitable resource is involved in, together with the interactions that characterise both of these aspects, constitute what is known as *Fishery Science*.

## The future and how to approach it

Having examined the basic concepts concerning how models are conceived in order to understand the dynamics of exploited populations, one can see how it becomes a progressive chain of factors that are in principle separate (exploited population and the mechanism of exploitation) until an attempt is made to bring them all together in a wider context that is formed of their ecosystem (in terms of the biological research of the resource). As for exploitation, this facet tends to be related with the group of broader strategies that determine the socioeconomics of fishing. This latter aspect has received little attention by the researchers of fishery population dynamics. Nevertheless, the pressure that fishing exerts must also undoubtedly be added to the advances made by the ECOPATH-type models in an assessment of the ecological network where the resource is found. A model which is developed to clearly and flexibly show the relationships between the different components of an ecosystem and that has been developed to a certain strategic level,

considering all of the difficulties that are involved, would undoubtedly not be sufficiently developed in terms of the socio-economic approach. This is especially important if one tries to introduce this concept into the overall model of the behaviour of fishing.

MARGALEF (1976) proposes a formula derived from the LOTKA-VOLTERRA expression with the following formula:

$$\frac{dN_p}{dt} = r_p N_p - bN_p^2 - VN_p N_h$$

where  $N_h$  is equal to fishing population, which is similar to a kind of fishing effort. Variations in this value would be as follows:

$$\frac{dN_h}{dt} = mdN_n - \omega N_{p(t-\tau)} - N_{h(t-\tau)}$$

where  $md$  would be the cost per unit of fishing effort and the drift in time, which is equal to the time necessary for the fishing change, given a specific fishing strategy. This delay is a very frequent aspect in ecological/biological/economic processes and it is highly important to design strategies that can estimate it, even though this may be in just an approximate way.

This here is obviously an initial approach although one should bear in mind that interaction between the strictly ecological and the economic models occurs by following guidelines, regulations and controls that have been extensively developed although where the level of uncertainty (HILBORN-WALTERS, 1992) is particularly relevant. This situation is again support on the concept of precautionary fishing.

In this respect, the future of fishery science will be situated somewhere between estimations made of the exploited resource in the context of the ecosystem's dynamics (the eco-

logical aspect) and the dynamics of the socio-economic network. Both of these two facets are clearly firmly based on scientific foundations that are characteristic of both branches of science. Fishery science gets its particular characteristics from the fact that the inclusion of both strategies occurs in a clearly specific way. A guide model could be considered to have the following aspects; an economic structure with particular characteristics that derive from the nature of its objective (a highly vulnerable resource); economic pressure that brings to bear on the massive components of the network of the trophic chain; and lastly a social action that tries to maintain an equilibrium between the two actions and which has a high degree of uncertainty as its greatest difficulty.

While the LOTKA-VOLTERRA approaches, together with the contributions made by ANCONA (1964), are now considered too old-fashioned, it is necessary to revise the points of view expounded by them because they are considered to be basic instruments for making progress in this direction. The fundamental elements are:

$$\frac{dN_p}{dt} = V_p - N_p$$

$$\frac{dN_d}{dt} = m_d - N_d$$

$N_p$  = population of the prey;  $N_d$  = population of the predator;  $r$  = rate of increase of the prey;  $m_d$  = mortality rate of the predator. The interaction produces a decrease in  $N_p$  in proportion to  $N$ . Also, the mortality rate of the prey

$$mp = v N_d$$

$N$  increases its biomass according to  $N_p$ .

$$vd = wN_p$$

In the previous equations,  $v$  and  $w$  are rates of relationship.

So, finally

$$\frac{dN_p}{dt} = r_p N_p - VN_p \cdot N_d$$

$$\frac{dN_d}{dt} = \omega N_d N_p - m_d \cdot N_d$$

These relationships clearly do not take the influence of other species that interact in the ecosystem into account, as the ECOPATH model tries to state. The whole, made up of two species, will remain stationary if

$$r_p = m_p - VN_d$$

$$m_d = r_d = \omega N_p$$

Although this situation is considered to be stationary, oscillations can and do occur. As has already been mentioned, it is important to bear in mind the time lag effect that is very

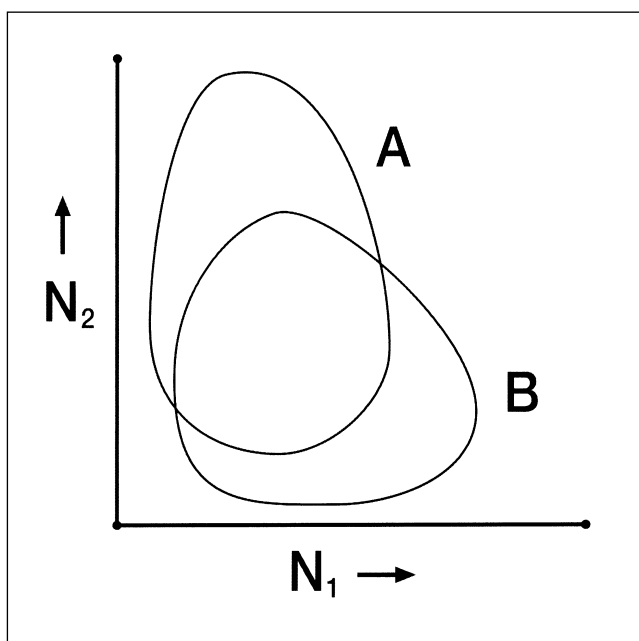

Figure 4. Relations between prey and depredator (from MARGALEF and D'ANCONA).  $N_1$ : prey.  $N_2$ : depredator. Two relations prey/depredator.

evident in some relationships and that disturbs the situation of equilibrium. If  $K_p$  and  $K_d$  are considered to be the values of  $N_p$  and  $N_d$  in the case of mixed populations in a stationary situation, the following equations are obtained:

$$K_p = m_p / \omega$$

$$K_d = r_p / V$$

It can also be considered that

$$\frac{N_p}{K_p} = n_p$$

$$\frac{N_d}{K_d} = n_d$$

when the population stays highly stationary and in this case  $n_p = n_d = 1$ .

The most serious difficulties arise, on the one hand, from the lack of specific knowledge of the behaviour of the systems that interact and, on the other, from the lack of specific instruments for processing the information. It has already been mentioned that a lot of problems are created as a result of the degree of uncertainty that arises from the lack of a correct understanding of the bioecology, on the one hand, and of the socio-economics, on the other, together with the lack of reliable information. A process as important as the stock reproducer/recruits relationship seems to adapt well to a cyclical type of analysis (SOLARI et al, 1998; BAS et al, 1999). It is also important here to consider that some of the constants accounted for in these last formulae appear to have a fractal structure.

Consideration of the elasticity of population sets together with the methodology fuzzy sets theory may possibly offer important opportunities as an instrument of mathematical processing.

The analysis of elasticity enables the effects of changes in survival, growth and reproduction in a particular bioecological level with a complex biology to be estimated and compared. It is a new instrument in the study of population dynamics and its application is highly important for the conservation and management of populations. Demographic parameters are taken into account, together with the asymptotic value of the population growth. This new view is highly important at the present time for the assessment of populations because it is easy to calculate and there is an obvious connection with the empirical data. Fewer data are needed and populations can be generalised with a wide range of biological features. Furthermore, the analysis of elasticity enables the functional dependence of population growth and demographic parameters to be explored. Prospective and retrospective analyses can be combined and explored to add to the understanding of the growth of populations, variations in the life expectancy rate and the level of uncertainty in the application of conservation measures. It is also interesting to be able to relate demographic

studies with biological and genetic evolution and thus help find the most appropriate form of management in each case. Despite the fact that the concepts of elasticity, susceptibility, convenience and gradient selection are not always sufficiently clear, they do help to relate demography with evolutionary dynamics in a constructive way. Different considerations that refer to this matter suggest that general recommendations on control can be made from an understanding of the species' biology. In some cases, variability and density-dependence are highly important although research needs to be implemented in any case because sufficient information is not available for the majority of species. (HEPPELL, PFISTER, de KROON, 2000).

Lastly, while there are many considerations that could be expressed to round off these thoughts, the concept expounded by SHERMANN and collaborators (large marine ecosystems, LME) may well provide the best set of proposals for action in terms of the more immediate future, provided that the different ecological and socio-economic components are dealt with within the lines of current research. The contribution made by the ideas of LME is also important because, and to repeat this fact one final time, this comprises the different bio-ecological and socio-economic components in an interactive and iterative way.

Finally it is necessary to consider the evolutionary ecology in assessment and management fish stocks (HUTCHINGS, 2000) and to consider commercial fishing as a massive, uncontrolled, experiment in evolutionary selection and its effects on several adaptative traits (STOKES and LAW, 2000). In summary evolutionary ecology will improve the success of fishery resource management in long term and, thereby, support the sustainable management of the world's fish resources.

## Bibliography

- [1] Allen, K.R. 1966. Some methods for estimating exploited populations. *J. Fish. Res. Bd. Can.* 23: 1553-1574.
- [2] Allen, P.M. and J.M. McGlade. 1986. Modelling complexity: the dynamics of discovery and exploitation in a fishery example. *Ext. Mond. Dev.* No 54-55.
- [3] Allen, P.M. and J.M. McGlade. 1987. Modelling and complex human systems: A fishery example. *Eur. J. Op. Res.* 30: 147-167.
- [4] Altukhov, Y.P. and E.A. Salmenkova. 1981. Applications of the stock concept to fish populations in the USSR. *Can. J. Fish. Aquat. Sci.* 38:1591-1600.
- [5] Alverson, D.L. and G.J. Paulik. 1973. Objectives and problems of managing aquatic living resources. *J. Fish. Res. Bd. Can.* 30:1936-1947.
- [6] Andrew, P.A. and D.S. Butterworth. 1987. Is  $F_{0.1}$  and appropriate harvesting strategy for the cape hakes?. *S. Afr. J. Mar. Sci.* 5:925-935.
- [7] Arditi, R. and H. Saia. 1992. Empirical evidence of the role of heterogeneity in ratio dependent consumption. *Ecology*, 73 (5), 1544-1551.
- [8] Armstrong, M.J. and P.A. Shelton. 1988. Bias in estima-

- tion of stock-recruit function parameters caused by non random environmental variability. *Can. J. Fish. Aquat. Sci.* 45:554-557.
- [9] Babayan, V.K. and Z.I. Kizner. 1988. Dynamic models for TAC assessment; logic, potentialities, development. *Coll. Scient. Pap. Int. Comm. SE. Atl. Fish.* 15(1):55-68.
- [10] Baltensweiler, W. 1964. *Zeiraphera griseana* Hubner (Lepidoptera: Tortricidae) in the European Alps. A contribution to the problem of cycles. *Can. Entomol.* 96:792-800.
- [11] Baranov, F.I. 1918. On the question of the biological basis of fisheries. *Nauchn. Issled. Ikhtologicheskii Inst. Izv.* 1:81-128.
- [12] Bard, Y. 1974. *Nonlinear Parameter Estimation*. Academic Press, New York.
- [13] Bartoo, N.W. and K.R. Parker. 1983. Stochastic age-frequency estimation using the von Bertalanffy growth equation. *Fish. Bull.* 81:91-96.
- [14] Beamish, R.J. and G.A. McFarlane. 1983. The forgotten requirement for age validation in fisheries biology. *Trans. Am. Fish. Soc.* 112:735-743.
- [15] Barryman, A .A. 1992. The origin and evolution of predator-prey theory. *Ecology*, 73(5):1530-1535.
- [16] Bas, C., E. Morales and M. Rubió. 1955. *La Pesca en España. I. Catalunya*. Inst. Inv. Pesq. 465 pp. Barcelona.
- [17] Bas, C., A.P. Solari and J.M. Martin. 1999. Observations over a new recruitment model for exploited fish populations. *Mem. Real Academia Ciencias y Artes de Barcelona*. n. 960; V. 58(5); 29 pp.
- [18] Beddington, J.R. and R.M. May. 1977. Harvesting natural populations in a randomly fluctuating environment. *Science* 197:463-465.
- [19] Beddington, J.R. and D.B. Taylor. 1973. Optimum age specific harvesting of a population. *Biometrics* 29:801-809.
- [20] Berger, J.O. 1985. *Statistical decision theory and Bayesian Analysis* (second edition). Springer Verlag, N.Y. 617 p.
- [21] Beverton, R.J.H. and S.J. Holt. 1956. A review of methods for estimating mortality rates in fish populations, with special references to sources of bias in catch sampling. *Rapp. P. V. Reun. Cons. Int. Explor. Mer.* 140:67-83.
- [22] Beverton, R.J.H. and S.J. Holt. 1957. *On the dynamics of exploited fish populations*. Fisheries Investment Series 2, Vol. 19 U.K. Ministry of Agriculture and Fisheries, London.
- [23] Bhattacharya, C.G. 1967. A simple method of resolution of a distribution into Gaussian components. *Biometrics* 23:115-135.
- [24] Bohlin, T. and B. Sundstrom. 1997. Influence of unequal catchability on population estimates using the Lincoln index and the removal method applied to electrofishing. *Oikos* 28:123-129.
- [25] Boronov, F.I., 1918. The biological basis of fisheries USSR. *Rep. Div. Fish. Mangement and Sci. Studies of Fish. Ind.* 1; nº 1.
- [26] Botsford, L.W. 1981. *Optimal fishery policy for size-specific density-dependent population models*. *J. Math. Biol.* 12:265-293.
- [27] Box, G.E.P. and G.M. Jenkins. 1976. *Time Series Analysis: Forecasting and Control*. Holden Day, San Francisco.
- [28] Bradford, M.J. and R.M. Peterman. 1989. Incorrect parameter used in virtual population analysis (VPA) generate spurious time trends in reconstructed abundances. In: R.J. Beamish and S.A. MacFarlane (Eds.) *Effects of Ocean Variability on Recruitment and on Evaluation of Parameters Used in Stock Assessment*. Canadian Special Publications on Fisheries and Aquatic Science, No. 108. pp. 87-99.
- [29] Brouard, F. and R. Grandperrin. 1985. Deep-bottom fishes of the outer reef slope in Vanuatu. Working paper 12, Seventeenth Regional Technical Meeting on Fisheries, South Pacific Commission, Noumea, New Caledonia
- [30] Browman, H.I.-2000. «Evolution of Fisheries Science» *Mar. Ecol.* p.s. 208;299-313.
- [31] Burnham, K.P., D.R. Anderson, G.C. White, C. Brownie, and K.H. Pollock. 1987. *Design and Analysis Methods for Fish Survival Experiments Based on Release-Recapture*. American Fisheries Society. Monograph 5. Bethesda, Maryland.
- [32] Butterworth, D.S. and P.A. Andrew. 1984. Dynamic catch-effort models for the hake stocks in ICSEAF Divisions 1.3 to 2.2. *Coli. Scient. Pap. Int. Comm. S.E. Atl. Fish.* 11:29- 58.
- [33] Caddy, J.F. 1975. Spatial model for an exploited shellfish population, and its application to the Georges Bank scallop fishery. *J. Fish. Res. Bd. Can.* 32:1305-1328.
- [34] Caddy, J .F .and G .P .Bazigos. 1985. Practical guidelines for statistical monitoring of fisheries in manpower limited situations. *FAO Fisheries Technical Paper* 257.
- [35] Caddy, J.F. and J.A. Gulland. 1983. Historical patterns of fish stocks. *Mar. Policy* 7:267- 278
- [36] Cassie, R.M. 1954. Some uses of probability paper in the analysis of size frequency distributions. *Aust. J. Mar. Freshwater Res.* 5:513-522.
- [37] Caswell, H. and D.E. Weeks. 1986. Two-sex models: chaos, extinction, and other dynamic consequences of sex. *Am. Nat.* 128:707-735.
- [38] Charles, A.T. 1983b. Optimal fisheries investment under uncertainty. *Can. J. Fish. Aquat. Sci.* 40:2080-2091.
- [39] Clark, C.W. 1976. *Mathematical Bioeconomics: The Optimal Management of Renewable Resources*. John Wiley. New York.
- [40] Clark, C. W. 1980. Towards a predictive model for the economic regulation of commercial Fisheries. *Can. J. Fish. Aquat. Sci.* 37:1111-1129.
- [41] Clark, C. W. 1982. Concentration profiles and the production and management of marine fisheries. *In: W. Ei-*

- chorn, R. Henn, K. Neumann. and R. W. Shepard (Eds.) *Economic Theory of Natural Resources*. Physica-Verlag, Wurzburg-Wien, pp. 97-112.
- [42] Clark, C. W. 1985. *Bioeconomic Modelling and Fisheries Management*. Wiley, New York.
- [43] Clark, C., G. Edwards, and M. Friedlaender. 1973. Beverton-Holt model of commercial fisheries: optimal dynamics. *J. Fish. Res. Bd. Can.* 30:1629-1640.
- [44] Clark, C. W. and G.P. Kirkwood. 1979. Bioeconomic model of the Gulf of Carpentaria prawn fishery. *J. Fish. Res. Bd. Can.* 36:1304-1312.
- [45] Clark, I. 1979. *Practical Geostatistics*. Elsevier, London.
- [46] Cochran, W.G. 1977. *Sampling Techniques*. Wiley, New York.
- [47] Collie, J.S. and M.P. Sissenwine. 1983. Estimating population size from relative abundance data measured with error. *Can. J. Fish. Aquat. Sci.* 40:1871-1879.
- [48] Conover, D.O. – 2000. Darwinian fishery science. *Mar. Ecol. P.S.* 208: 303-307.
- [49] Courchamp, F., T. Clutton-Brock and B. Grenfell. – 1999. Inverse densitydependence and the Allee effect. *Tree*. 14: 405-410.
- [50] Crutchfield, J.A. (Ed.) 1965. *The fisheries Problems in Resource Management*. University Washington Press. Seattle.
- [51] Crutchfield, J.A. 1979. Economic and social implications of the main policy alternatives for Controlling fishing effort. *J. Fish. Res. Bd. Can.* 36:742-752
- [52] Csirke, J. and J.F. Caddy, 1983. Production modelling using mortality estimates. *Can. Fish. Aquatic Sci.* 40: 43-51.
- [53] Csirke, J. and G.D. Sharp. 1984. Reports of the expert consultation to examine changes in abundance and species composition of neritic fish resources. FAO Fisheries Report No. 291.
- [54] Cushing, D.H. 1971. The dependence of recruitment on parent stock in different groups of fishes. *J. Cons. Int. Explor. Mer.* 33:340-362.
- [55] Cushing, D. 1982. *Climate and Fisheries*. Academic Press, London.
- [56] Cushing, D.H., 1996. Towards a science of recruitment in Fish Populations.
- [57] Cushing, D.H. and J.G.K. Harris. 1973. Stock and recruitment and the problem of density-dependence. *Rapp. P.-V. Reun. Cons. Explor. Perm. Int. Mer* 164:142-155.
- [58] Daan, N. 1987. Multispecies versus single-species assessment of North Sea fish stocks. *Can. J. Fish. Aquat. Sci.* 44 (Suppl. 2):360-370.
- [59] De Klerk, P. and M. Gatto. 1981. Some remarks on periodic harvesting of a fish population. *Math. Biosci.* 56:47-69.
- [60] De Lury, D.B. 1947. On the estimation of biological populations. *Biometrics* 3:145-167.
- [61] Deriso R.B. 1985b. Stock assessment and new evidence of density-dependence. *In: Fisheries Dynamics: Harvest, Management. and Sampling*, Washington Sea Grant 85-1, Seattle, pp. 49-60.
- [62] Deriso, R.B. 1987. *Optimal  $F_{0.1}$  criteria and their relationship to maximum sustainable yield*. *Can. J. Fish. Aquat. Sci.* 44(Suppl. 2):339-348.
- [63] Doubleday, W.G. 1976b. Environmental fluctuations and fisheries management. *ICNAF, Sel. Pap.* 1:141-150.
- [64] Edwards, A.W.F. 1972. *Likelihood: An Account of the Statistical Concept of Likelihood and its Applications to Scientific Inference*. Cambridge University Press, Cambridge.
- [65] Efron, B. 1979. Bootstrap methods: another look at the jackknife. *Ann. Stat.* 7:1-26.
- [66] Efron, B. 1981. Non parametric estimates of standard error: the jackknife, the bootstrap and other methods. *Biometrika* 68:589-599.
- [67] Efron, B. 1982. The jackknife, the bootstrap and other resampling plans. *SIAM-CBMS* 38:1-92.
- [68] Efron, B. 1985. Bootstrap confidence intervals for a class of parametric problems. *Biometrika* 72:45-58.
- [69] Efron, B. 1987. Better bootstrap confidence intervals. *J. Am. Stat. Assoc.* 82:171-185.
- [70] Fabens, A.J. 1965. Properties and fitting of the von Bertalanffy growth curve. *Growth* 29:265-289.
- [71] Fournier, D.A. and C. Archibald. 1982. A general theory for analyzing catch at age data. *Can. J. Fish. Aquat. Sci.* 39:1195-1207.
- [72] Fournier, D.A. and P.A. Breen. 1983. Estimation of abalone mortality rates with growth analysis. *Trans. Am. Fish. Soc.* 112:403-411.
- [73] Fournier, D.A. and A.R. Warburton. 1989. Evaluating fisheries management models by simulated adaptive control-introducing the composite model. *Can. J. Fish. Aquat. Sci.* 46:1002-1012.
- [74] Fox, W.W. 1975. Fitting the generalized stock production model by least-squares and equilibrium approximation. *U.S. Fish. Bull.* 73:23-37.
- [75] Fried, S.M. and R. Hilborn. 1988. Inseason forecasting of Bristol Bay, Alaska, sockeye salmon (*Oncorhynchus nerka*) abundance using Bayesian probability theory. *Can. J. Fish. Aquat. Sci.* 45:850-855.
- [76] Garcia, S. 1984. The problems of unstable resource management. FAO publication CECAF/ECAF Series 84/28.
- [77] Garrod, D.J. 1969. Empirical assessments of catch/effort relationships in North Atlantic cod stocks. *Int. Comm. NW Atl. Fish. Res. Bull.* 6:26-34.
- [78] Getz, W.M., G.L. Swartzman, and R.C. Francis. 1985. A conceptual model for multi-species, multifleet fisheries. *Lect. Notes Biomath.* 61:49-63.
- [79] Ginzburg, L.R. and H.R. Arkakaxa, 1992. Consequences of ratio-dependent predation for steady-state properties of ecosystems. *Ecology*, 73(5): 1536-1543.
- [80] Glantz, M.H. 1979. Science, politics and economics of the Peruvian anchoveta fishery. *Mar. Policy* 3:201-210.
- [81] Gordon, H.S. 1953. An economic approach to the optimum utilization of fishery resources. *J. Fish. Res. Bd. Can.* 10:442-457.

- [82] Graham, M.– 1929. Studies on the age determination in fish. Part II. Fish. Inv. Series II. vol. XI, No. 3. London.
- [83] Graham, M. 1935. Modern theory of exploiting a fishery and application to North Sea trawling. J. Cons. Int. Explor. Mer. 10:264-274.
- [84] Graham, M. 1939. The sigmoid curve and overfishing problem. Rapp. Cons. Expl. Mar. 110: 15-20.
- [85] Gulland, J.A. 1965. Estimation of mortality rates. Annex to Arctic Fisheries Working Group Report (ICES, C.M. 1965. Doc. No.3. mimeographed).
- [86] Gulland, J.A. 1971. Science and fishery management. J. Cons. Int. Explor. Mer. 33:471-477.
- [87] Gulland, J. A. 1983. *Fish Stock Assessment: A Manual of Basic Methods*. Wiley, New York. 223 p.
- [88] Gulland, J.A. 1988. Fish population dynamics. N.Y. John Wiley and Sons. Edit.
- [89] Gutierrez, A.P. 1992. Physiological basis of ratio-dependent predator-prey theory: the metabolic pool model as a paradigm. Ecology, 73(5):1552-1563.
- [90] Hallier, J.P. 1985. Purse seining on debris-associated school in the western Indian Ocean. FAO TWS/85/30.
- [91] Harris, J.G.K. 1975. The effect of density-dependent mortality on the shape of the stock and recruitment curve. J. Cons. Int. Explor. Mer. 36:144-149.
- [92] Heppell, S., C. Pfister, H. de Kroon 2000. Elasticity analysis in population biology. Methods and applications. Special feature Ecology. 21(3): 605-606.
- [93] Hilborn, R. 1976. Optimal exploitation of multiple stocks by a common fishery: a new methodology. J. Fish. Res. Bd. Can. 33:1-5.
- [94] Hilborn, R. 1979. Comparison of fisheries control systems that utilize catch and effort data. J. Fish. Res. Bd. Can. 36:1477-1489.
- [95] Hilborn, R. 1985c. Simplified calculation of optimum spawning stock size from Ricker's stock recruitment curve. Can. J. Fish. Aquat. Sci. 42:1833-1834.
- [96] Hilborn, R. 1985d. A comparison of harvest policies for mixed stock fisheries. In: M. Mangel (Ed.) *Resource Management: Proceedings of the Second Ralf Yorque Workshop*, Lecture , Notes in Biomathematics No. 61. Springer-Verlag, Berlin. pp. 75-87.
- [97] Hilborn, R. 1990. Determination of fish movement patterns from tag recoveries using maximum likelihood estimators. Can. J. Fish. Aquat. Sci. 47:635-643.
- [98] Hilborn, R. and R.B. Kennedy. 1991. Spatial pattern in catch rates: a test of economic theory. J. Math. Biol. in press.
- [99] Hilborn, R. and M. Ledbetter. 1985. Determinants of catching power in the British Columbia salmon purse-seine fleet. Can. J. Fish. Aquat. Sci. 42:51-56.
- [100] Hilborn, R. and J. Sibert. 1988. Adaptive management of developing fisheries. Mar. Policy 12:112-121.
- [101] Hilborn, R. and C.J. Walters. 1987b. A general model for simulation of stock and fleet dynamics in spatially heterogeneous fisheries. Can. J. Fish. Aquat. Sci. 44:1366-1369.
- [102] Hilborn, R. and C.J. Walters, 1992. Quantitative fisheries stock assessment, Choice, Dynamics and Uncertainty. Ed. Chapman and Hall. N.Y. , London. 570 pp.
- [103] Hjort, J. 1908. Some results of the International Ocean Researches. Scottish Ocean: Lab. Edimburgh.
- [104] Hjort, J. 1914. Fluctuations in the great fisheries of northern Europa. Rapp. Conseil Expl. Mer. XX. Copenhagen.
- [105] Hjort, J., G. Jahn., and P. Ottestad. 1933. The optimum catch. Hvalradets Skr. 7:92-127.
- [106] Hjort, J. and J.T. Ruud. 1938. Deep sea prawn fisheries and their problems. Hvalradets Skrifter. 17 Oslo.
- [107] Hoenig, J.M., W.D. Lawing, and N.A. Hoenig. 1983. Using mean age, mean length, and median length data to estimate the total mortality rate. Int. Council. Explor. Sea C.M. 23:1-11.
- [108] Holling, C.S. 1973. Resilience and stability of ecological systems. Ann. Rev. Ecol. Syst. 4: 1-23.
- [109] Hulme, H.R., R.J.H. Beverton and S.J. Holt. 1947. Population studies in fisheries biology. Nature 159: 714-715.
- [110] Hutchings, J.A. 2000. Numerical assessment in the front seat ecology and evolution in the back seat: time to change drivers in fisheries and aquatic science?. Mar. Ecol. P.S. 208: 299-303.
- [111] ICES. 1988. Report of the workshop on methods of fish stock assessment. International Council for the Exploration of the Seas, Copenhagen, Denmark.
- [112] IFREMER. 1987. Assessment of technical interactions in mixed fisheries: Report of a workshop held at IFREMER in Nantes (France) under the auspices of EEC (DG XIV). IFREMER BP. 1049, 44037 Nantes CEDEX France.
- [113] Jarre-Teichmann, A. 1998. The potential role mass balance mode for the management of upwelling ecosystems. Ecol. Applic. 8(1) suppl. 1998: s93-s103.
- [114] Jennings, S., Pinnegar, J.K., Polunin, N.V.C., and Warr, K.J. Impacts of trawling disturbance on the trophic structure of benthic invertebrate communities. Mers (in press).
- [115] Johannesson, K.A. and R.B. Mitson. 1983. Fisheries acoustics: a practical manual for aquatic biomass estimation. FAO Fisheries Technical Paper 240.
- [116] Johnson, B.L. and C. Waiters. 1988. Estimation of abundance and survey catchability from catch-at-age and survey data. Can. J. Fish. Aquat. Sci. (submitted).
- [117] Jones, R. 1961. The assessment of long-term effects of changes in gear selectivity and fishing effort. Mar. Res. (Scotland) 1961(2):1-19.
- [118] Jones, R. 1981. The use of length composition data in fish stock assessment (with notes on V PA and cohort analysis). FAO Fisheries Circular No. 734.
- [119] Jones, R. 1984. Assessing the effects of changes in exploitation pattern using length composition data (with notes on VPA and cohort analysis). FAO Fisheries Technical Paper No. 256.
- [120] Kerherve, Ph. Miragawa, S. Heussner, and A. Monaco. 2001. Stable isotopes ( $^{13}\text{C}/^{12}\text{C}$  and  $^{15}\text{N}/^{14}\text{N}$ ) in



- setting organic matter of the Northwestern Mediterranean sea: biochemical implications *Ocean. Acta*. 24, (suppl.) 2001; 77-86.
- [121] Kerr, S.R. and R.A. Ryder. 1989. Current approaches to multispecies analysis of marine fisheries. *Can. J. Fish. Aquat. Sci.* 46:528-534.
- [122] Kohler, S.E.A. Parkov and C.D. McQuaid. 2000. Trophic structure of marine food-web at the Prince Eduard Islands (southern Ocean) determined by  $\delta^{13}\text{C}$ . and  $\delta^{15}\text{N}$ . analysis. *Mar. Ecol. Prog. Ser.* 208: 13-20.
- [123] Laevastu, T., F. Favorite, and H. A. Larkins. 1982. Resource assessment and evaluation of the dynamics of the fisheries resources in the northeastern Pacific with numerical ecosystem models. In: M.C. Mercer, (Ed.). *Multispecies Approaches to Fisheries Management Advice*. Canadian Special Publications in Fisheries and Aquatic Sciences, No. 59.
- [124] Lane, D.E. 1988. Investment decision making by fishermen. *Can. J. Fish. Aquat. Sci.* 45:782-796.
- [125] Larkin, P.A., and W.E. Ricker. 1964. Further information on sustained yields from fluctuating environments. *J. Fish. Res. Bd. Can.* 21:1-7.
- [126] LaPointe, M.F., R.M. Peterman, and A.D. MacCall. 1989. Trends in fishing mortality rate along with errors in natural mortality rate can cause spurious time trends in fish stock abundances estimated by virtual population analysis (VPA). *Can. J. Fish. Aquat. Sci.* 46:2129-2139.
- [127] Lasker, R. and A. MacCall. 1983. New ideas on the fluctuations of the clupeoid stocks off California. pp. 110-120 In: CNC/SCOR. *Proceedings of the Joint Oceanographic Assembly 1982 – General Symposia*. Canadian National Committee/Scientific Committee on Ocean Research. Ottawa, Ontario 189 p.
- [128] Laurec, A. and J.G. Shepherd. 1983. On the analysis of catch and effort data. *J. Cons. Int. Explor. Mer* 41:81-84.
- [129] Lawson, T.A. and R. Hilborn. 1985. Equilibrium yields and yield isopleths from a general age-structured model of harvested populations. *Can. J. Fish. Aquat. Sci.* 42:1766-1771.
- [130] Leonart, J. and J. Salat. 1989. A dynamic approach to catch-effort data analysis using a new concept: the inertia of the stock. *Can. J. Fish. Aquat. Sci.* 46:1367-1374.
- [131] Leonart, J., J. Salat, and B. Roel. 1985. A dynamic production model. *Colln. Scient. Pap. Int. Comm. SE. Atl. Fish* 12(1):119-146.
- [132.] Lotka, A.J. 1925. *Elements of Physical Biology*. Williams and Wilkins, Baltimore.
- [133] Ludwig, D. 1981. Harvesting strategies for a randomly fluctuating population. *J. Const. Int. Explor. Mer.* 39: 168-174.
- [134] Ludwig, D. and C.J. Walters. 1981. Measurement errors and uncertainty in parameter estimates for stock and recruitment. *Can. J. Fish. Aquat. Sci.* 38:711-720.
- [135] Ludwig, D. and C.J. Walters. 1985. Are age structured models appropriate for catch-effort data? *Can. J. Fish. Aquat. Sci.* 42:1066-1072.
- [136] Ludwig, D. and C.J. Walters. 1989. A robust method for parameter estimation from catch and effort data. *Can. J. Fish. Aquat. Sci.* 46:137-144.
- [137] Ludwig, D., C.J. Walters, and J. Cooke. 1988. Comparison of two models and two estimation methods for catch and effort data. *Nat. Res. Model* 2:457-498.
- [138] MacCall, A.D. 1984. Population models of habitat selection, with application to the northern anchovy. National Marine Fisheries Service, Southwest Fisheries Centre, Admin. Rept. No. LJ-84-01.
- [139] MacCall, A.D. 1990. *Dynamic Geography of Marine Fish Populations*. University of Washington Press, Seattle.
- [140] MacDonald, P.D.M. and T.J. Pitcher. 1979. Age groups from size-frequency data: a versatile and efficient method of analysing distribution mixtures. *J. Fish. Res. Bd. Can.* 36:987-1001.
- [141] Mace, P.M. and I.J. Doonan. 1988. A generalized bioeconomic simulation model for fish population dynamics. *N.J. Fish. Ass. Res. Doc.* 88/4.
- [142] Mahon, R. 1980. Accuracy of catch-effort methods for estimating fish density and biomass in streams. *Env. Biol. Fish.* 5:343-360.
- [143] Mangel, M. 1985. *Decision and Control in Uncertain Resource Systems*. Academic Press, New York.
- [144] Mangel, M. and C.W. Clark. 1988. *Dynamic Modelling in Behavioral Ecology*. Princeton University Press, Princeton, NJ.
- [145] Margalef, R. 1990. Population dynamics with succession theory. XXV Symposium Biol. Mar. Ferrara. 10-15-IX-1990.
- [146] May, R.M. 1973. *Stability and Complexity in Model Ecosystems*. Princeton University Press, Princeton, NJ.
- [147] May, R.M. 1976. Simple mathematical models with very complicated dynamics. *Nature*, 261:459-467.
- [148] May, R.M. (Ed.). 1984. *Exploitation of Marine Communities. Report of the Dahlem Workshop on Exploitation of Marine Communities*. Berlin, April 1-6, 1984. Life Sciences Research Report 32. Springer-Verlag, Berlin.
- [149] May, R.M. R. Beddington, J.W. Horwood, and J.G. Shepherd. 1978. Exploiting natural populations in an uncertain world. *Math. Biosci.* 42:219-252.
- [150] McGlade, J.M. and P.M. Allen. 1984. The fishing industry as a complex system. In: R. Mahon (Ed.) *Toward the Inclusion of Fishery Interactions in Management Advice*. Canadian Technical Report on Fisheries and Aquatic Science No. 1347, pp. 209-216.
- [151] Meinhold, R.J. and N.D. Singpurwalla. 1983. Understanding the Kalman filter. *Am. Stat.* 37:123-127.
- [152] Methot, R.D. 1989. Synthetic estimates of historical abundance and mortality for northern anchovy. *Am. Fish. Soc. Symp.* 6:66-82.

- [153] Millington, P. 1984. The fishermen as predator: numerical responses of British Columbia, gillnet fishermen to salmon abundance. MS Thesis. Department of Zoology. University of British Columbia. Vancouver.
- [154] Mittertreiner, A. and J. Schnute. 1985. Simplex: a manual and software package for easy nonlinear estimation and interpretation in fishery research. Canadian Technical Report on Fisheries and Aquatic Science, No. 1384.
- [155] Mohn, R.K. 1980. Bias and error propagation in logistic models. *Can. J. Fish. Aquat. Sci.* 37:1276-1283.
- [156] Moussalli, E. and R. Hilborn. 1986. Optimal stock size and harvest rate in multistage life history models. *Can. J. Fish. Aquat. Sci.* 43:135-141.
- [157] Munro, J.L. 1980. Stock assessment models: applicability and utility in tropical small-scale fisheries. In: S.B. Saila and P.M. Roedel (eds.) *Stock Assessment for Tropical Small-scale Fisheries*. International Center Marine Resource Development, University of Rhode Island, Kingston.
- [158] Munro, J.L. and R. Thompson. 1983. The Jamaican fishing industry. In: J.L. Munro, (Ed.) *Caribbean Coral Reef Fish Resources*. ICLARM, Manila, Philippines.
- [159] Murawski, S.A. and J.S. Idoine. 1989. Yield sustainability under constant-catch policy and stochastic recruitment. *Trans. Am. Fish. Soc.* 118:349-367.
- [160] Murphy, G.I. 1965. A solution to the catch equation. *J. Fish. Res. Bd. Can.* 22:191-202.
- [161] Murphy, G. I. 1977. New understanding of southern bluefin tuna. *Aust. Fish.* 36:2-6.
- [162] Murphy, G.I. 1982. Recruitment of tropical fisheries. In: D. Pauly and G.I. Murphy (Eds.) *Theory and Management of Tropical Fisheries*. ICLARM Contribution, No. 105, Manila.
- [163] Myers, R.A., N.J. Barrowman, J.A. Hutchings, and A.S. Rosenberg. 1995. Population dynamics of exploited fish stocks at low population levels. *Science*, 269: 1106-1108.
- [164] Nansen, F. 1924. *Hunting and Adventures in the Arctic*. Kristiania, Oslo.
- [165] Nelder, J.A. and R. Mead. 1965. A simplex method for function minimization. *Comput. J.* 7:308-313.
- [166] O'Neill, R.V. 1973. Error analysis of ecological models. Report presented at the Third National Symposium on Radioecology in 1971. Deciduous Forest Biome Memo Report 71- 15.
- [167] Pacific Salmon Commission. 1988. 1987 Annual report of the joint chinook technical committee. TCCHINOOK 88-2 Appendix II, Supplement B. Vancouver, Canada.
- [168] Paloheimo, J.E. 1980. Estimation of mortality rates in fish populations. *Trans. Am. Fish. Soc.* 109:378-386.
- [169] Paloheimo, J.E. and L.M. Dickie. 1964. Abundance and fishing success. *Rapp. P.-C. Reun. Cons. Perm. Int. Explor. Mer* 155:152-163.
- [170] Parish, B.B. (Ed.) 1973. *Fish Stocks and Recruitment*. Rapp. P.-V. Reun. Vol. 164.
- [171] Paulik, G. J. 1961. Detection of incomplete reponing of tags. *J. Fish. Res. Bd. Can.* 18:817-832.
- [172] Paulik, G.J., A.S. Hourston, and P.A. Larkin. 1967. Exploitation of multiple stocks by a common fishery. *J. Fish. Res. Bd. Can.* 24:2527-2537.
- [173] Pauly, D. 1984. *Fish Population Dynamics in Tropical Waters: a Manual for Use with Programmable Calculators*. ICLARM, Manila.
- [174] Pauly, D. and G.R. Morgan (Eds.). 1987. *Length-Based Methods in Fisheries Research*. ICLARM Conference Proceedings, No. 13, ICLARM, Manila.
- [175] Pauly, D, and L. Tsukayama (Eds). 1987. *The Peruvian Anchoveta and its Upwelling Ecosystem: Three Decades of Change*. ICLARM Studies and Reviews, No. 15, ICLARM, Manila.
- [176] Pauly, D., M.L. Palomares, and F.C. Gayanilo. 1987. VPA estimates of monthly population length composition, recruitment, mortality, biomass and related statistics of Peruvian anchoveta, 1953-1981. In: D. Pauly and L. Tsukayama (Eds). 1987. *The Peruvian Anchoveta and its Upwelling Ecosystem: Three Decades of Change*. ICLARM Studies and Reviews, No. 15. ICLARM, Manila, pp. 142-166.
- [177] Pella, I.1. and P.K. Tomlinson. 1969. A generalized stock production model. *Bull. Inter-Am. Trop. Tuna Comm.* 13:419-496.
- [178] Peterman, R.M. 1975. New techniques for policy evaluation in ecological systems: methodologies for a case study of Pacific salmon fisheries. *J. Fish. Res. Bd. Can.* 32:2179- 2188.
- [179] Peterman, R.M. 1977. Graphical evaluation of environmental management options: examples from a forest-insect pest system. *Ecol. Model.* 3:133-148.
- [180] Peterman, R.M. 1980. Dynamics of native indian food fisheries on salmon in British Columbia. *Can. J. Fish. Aquat. Sci.* 37:561-566.
- [181] Peterman, R.M. and M. Gatto. 1978. Estimation of functional responses of predators on juvenile salmon. *J. Fish. Res. Bd. Can.* 35:797-808.
- [182] Petersen, C.G.J. 1892. Fiskensbiologiske forhold I Holboek Fjord, 1890-91. *Beret. Danske Biol. Sta.* 1890-91, 1:121-183.
- [183] Pikitch, E.K. 1988. Objectives for biologically and technically interrelated fisheries. In: W.S. Wooster (Ed.) *Fisheries Science and Management: Objectives and Limitations*. Lecture Notes on Coastal and Estuarine Studies, No. 28 Springer-Verlag. New York, Chapter 5, pp. 107-136.
- [184] Polovina, J.J. 1989. A system of simultaneous dynamic production and forecast models for multispecies or multiarea applications. *Can. J. Fish. Aquat. Sci.* 46:961-963.
- [185] Polunin, N.V.C and J.K. Rinnegar. 2000. Trophic level dynamics inferred from stable isotopes of the C. and N. Fishing down the Mediterranean food web? *Kerkyra* 26-30-VII-2000. CIESM Work-shop Series 12 6972.

- [186] Polunin, N.V.C. 2001 (in press). Marine protected areas, fish and fisheries. In P.J.B. Hart and J.D. Reynolds (edit). Handbook of fish and fisheries. Vol. II. Blackweel. Oxford.
- [187] Polunin, N.V.C., B. Morales-Nin, W.E. Pahisey, J.E. Cartes, J.K. Pinnegar and J. Morata. Feeding relationships in Mediterranean bathyal assemblages elucidated by carbon and nitrogen stable isotope data. MEPS (in press).
- [188] Polunin, N.V.C. and J. Pinnegar. 2002 (in press). Fishes in marine food-weeb. In P.J.B. Hart and J.D. Reynolds (edts.) Handbook of fish and fisheries. V.I Blackwell. Oxford.
- [189] Pope, J.G. 1972. An investigation of the accuracy of virtual population analysis using cohort analysis. IC-NAF Res. Bull. 9:65-74.
- [190] Pope, J.G. and B.J. Knight. 1982: Simple models of predation in multi-age multispecies fisheries for considering the estimation of fishing mortality and its effects. In: M.C. Mercer, (Ed.). *Multispecies Approaches to Fisheries Management Advice*, Canadian Special Publications on Fisheries and Aquatic Science, No. 59, pp. 64-69.
- [191] Pope, J.G. and J.G. Shepherd. 1985. A comparison of the performance of various methods for tuning VPAs using effort data. J. Cons. Int. Explor. Mer 42:129-151.
- [192] Post, D.M., M.L. Pale and N.G. Hairston, Jr. 2000. Ecosystem size determines food chain in lakes. Nature 405:147-149.
- [193] Postel, E. 1995. Contribution a l'etude de la biologie de quelques Scombridae de l'Atlantique tropico-oriental. Ann. Stn. Oceangr. Salammbou, 10:1-167 (cited in Pauly, 1984).
- [194] Powers, J.E. 1989. Multispecies models and chaotic dynamics. ICEM, No. 21.
- [195] Prince, J. D. 1989. The fisheries biology of the Tasmanian stocks of *Haliotis rubra*. Ph.D. Thesis, Department of Zoology, University of Tasmania.
- [196] Ralston, S. 1976. Age determination of a tropical reef butterfly fish utilizing daily growth rings in otoliths. Fish. Bull. 74:990-994.
- [197] Reed, W.J. 1978. The steady state of a stochastic harvesting model. Math. Biosci. 41:273-307.
- [198] Ricker, W.E. 1948. Methods of estimating vital statistics of fish populations. Indiana University Publications in Science Series, No. 15.
- [199] Ricker, W.E. 1954. Stock and recruitment. J. Fish. Res. Bd. Can. 11:559-623.
- [200] Ricker, W.E. 1958a. *Handbook of Computations for Biological Statistics of Fish Populations. Fisheries Research Board of Canada, Bulletin No. 119.*
- [201] Ricker, W.E. 1958b. Maximum sustained yields from fluctuating environments and mixed stocks. J. Fish. Res. Bd. Can. 15:991-1006.
- [202] Ricker, W.E. 1975. *Computation and Interpretation of Biological Statistics of Fish Populations.* Fisheries Research Board of Canada, Bulletin No. 191.
- [203] Robbins, H. and Monro. S. 1951. A stochastic approximation method. Ann. Math. Stat. 22:400-407.
- [204] Roedel, P.M. (Ed). 1975. *Optimum Sustainable Yield as a Concept in Fisheries Management.* Special Publication No. 9, American Fisheries Society.
- [205] Roff. D.A. 1983. Analysis of catch/effort data: a comparison of three methods. Can. J. Fish. Aquat. Sci. 40:1496-1506.
- [206] Rothschild, B.J. 1986. *Dynamics of Marine Fish Populations.* Harvard University Press, Cambridge. MA.
- [207] Royce, W.F. 1987. *Fishery Development.* Academic Press, New York. 248 pp.
- [208] Rusell, E.S. 1931. Some theoretical considerations on the over fishing problem. J. Cons. Per. Int. Exl. Mer. 6: 3-27.
- [209] Ryder. R.A., S.R. Kerr, K.H. Loftus, and H.A. Regier. 1974. The morphoedaphic index, a fish yield estimator – review and evaluation. J. Fish. Res. Bd. Can. 31:663-688.
- [210] Saila, S.B. 1983. Importance and assessment of discards in commercial fisheries. FAO Fisheries Circular No. 765.
- [211] Sainsbury. K. 1980. Effect of individual variability on the von Bertalanffy growth equation. Can. J. Fish. Aquat. Sci. 37:241-247.
- [212] Sainsbury, K. 1988. The ecological basis of multispecies fisheries. and management of a demersal fishery in tropical Australia. In: J. Gulland (Ed.) *Fish Population Dynamics.* Wiley, Chichester. pp. 349-382.
- [213] Schaefer, M.B. 1954. Some aspects of the dynamics of populations important to the management of commercial marine fisheries. Bull. Inter-Am. Trop. Tuna Comm. 1:27-56.
- [214] Schaefer, M.B. 1957. A study of the dynamics of the fishery for yellowfin tuna in the eastern tropical Pacific Ocean. Inter-Am. Trop. Tuna Comm. Bull. 2:247-285.
- [215] Schnute, J. 1977. Improved estimates from the Schaefer production model: theoretical considerations. J. Fish. Res. Bd. Can. 34:583-603.
- [216] Schnute. J. 1982. *A Manual for Easy Nonlinear Parameter Estimation in Fishery Research With Interactive Microcomputer Programs.* Canadian Technical Report on Fisheries and Aquatic Science, No. 1140.
- [217] Schnute, J. 1985. A general theory for analysis of catch and effort data. Can. J. Fish. Aquat. Sci. 42:414-429.
- [218] Schnute. J 1987. A general fishery model for a size-structured fish population. Can. J. Fish. Aquat. Sci. 44:924-940.
- [219] Shackleton, L.Y. 1987. A comparative study of fossil fish scales from three upwelling regions. S. Afr. J. Mar. Sci. 5:79-84.
- [220] Shepherd. J.G. and D.H. Cushing. 1980. A mechanism for density dependent survival of larval fish as the basis of a stock– recruitment relationship. J. Const. Int. Explor. Mer, 39:160-167.
- [221] Shepherd. I.G. and J.W. Horwood. 1977. The sensitivity of exploited populations to environmental «noise»,

- and the implications for management. *J. Const. Int. Explor. Mer.*, 38:318-323.
- [222] Shepard, M.P. and F.C. Withler. 1958. Spawning stock size and resultant production for Skeena sockeye. *J. Fish. Res. Bd. Can.* 15:1007-1025.
- [223] Schnute, J., L.J. Richards, and A.J. Cass. 1989. Fish survival and recruitment: investigations based on a size-structured model. *Can. J. Fish. Aquat. Sci.* 46:743-769.
- [224] Sissenwine, M.P. 1977. The effect of random fluctuations on a hypothetical fishery. *Int. Comm. Northw. Atlant. Fish., Sel. Pap.* 2:137-144.
- [225] Sissenwine, M.P. 1978. Is MSY an adequate foundation for optimum yield?. *Fisheries* 3(6):22-24,37:42.
- [226] Sissenwine, M.P. and J.G. Shepherd. 1987. An alternative perspective on recruitment overfishing and biological reference points. *Can. J. Fish. Aquat. Sci.* 44:913-918.
- [227] Skud, B.E. 1975. Revised estimates of halibut abundance and the Thompson-Burkenroad debate. *Int. Pac. Halibut Comm. Scientific Report No.* 56.
- [228] Skud, B.E. 1982. Dominance in fishes: the relation between environment and abundance. *Science* 216:144-149.
- [229] Slobodkin, L.B. 1992. A summary of the fluvial feature and comments on its theoretical context and importance. *Ecology*, 73 (5); 1564-1566.
- [230] Smith, G. G. M. 1940. Factors limiting distribution and size in the starfish. *J. Fish. Res. Bd. Can.* 5:84-103.
- [231] Smith, V.L. 1969. On models of commercial fishing. *J. Polit. Econ.* 77:181-198.
- [232] Solari, A.P., J.M. Martin, and C. Bas. 1997. Stock and recruitment in Baltic cod (*Gadus Morhua*): a new non-linear approach. *J. Cons. Int. Explor. Mer.* 40:67-15.
- [233] Soutar, A. and J.D. Isaacs. 1969. A history of fish populations inferred from fish scales in anaerobic sediments off California. *Calif. Mar. Res. Comm. CalCOFI*, 13:63-70.
- [234] Steele, J.H. and E.W. Henderson. 1984. Modeling long-term fluctuations in fish stocks. *Science* 224:985-987.
- [235] Stephens, P.A. and W.J. Southerland. 1999. Consequences of the Allee effect for behaviour, ecology and conservation. *TREE*, 14:401-405.
- [236] Stergiou, K. and N. Palunin. 2000. Executive summary Fishery down the Mediterranean food web?. *CIESM. Workshop Series. No. 12*; 7-18 pp.
- [237] Stokes, K. and R. Law. 2000. Fishing as an evolutionary force. *Mar. Ecol. P.S.* 208:307-309.
- [238] Sullivan, P.J., H.L. Lai, and V.F. Gallucci. 1990. A catch-at-length analysis that incorporates a stochastic model for growth. *Can. J. Fish. Aquat. Sci.* 47:184-198.
- [239] Thompson, W.F. 1936. Conservation of the Pacific Halibut. Annual Report, Smithsonian Institution for year ending. 30-vi 1935.
- [240] Thompson, W.F. and F.H. Bell. 1934. Biological statistics of the Pacific Halibut fishery. *Rept. Inst. Fish. Comin.* 8; 49 pp.
- [241] Tovar, H., V. Guillen and M.E. Nakama. 1987. Monthly population size of three guano bird species off Peru. In Pauly D. and I. Tsukayama (eds.). *The Peruvian Anchoreta and its upwelling ecosystem: three decades of change. ICLARM Studies and Reviews. No. 15 ICLARM Morila.* pp. 208-218.
- [242] Uhler, R. 1979. Least squares regression estimates of the Schaefer production model: some
- [243] Monte Carlo simulation results. *Can. J. Fish. Aquat. Sci.* 37:1284-1294.
- [244] Varley, G.C. 1949. Population change in German forest pests. *J. Arim. Ecol.* 18:117-122.
- [245] Vetter, E.F. 1988. Estimation of natural mortality in fish stocks: a review. *Fishery Bull.* 86 (1):5-43.
- [246] Von Bertalanffy, L. 1938. A quantitative theory of organic growth. *Hum. Biol.* 10:181-213.
- [247] Walters, C.J. 1985a. Bias in the estimation of functional relationships from time series data. *Can. J. Fish. Aquat. Sci.* 42:147-149.
- [248] Walters, C.J. 1985b. Approaches to adaptive policy design for harvest management. In: Vincent, T.L., Y. Cohen, W.J. Grantham, G.P. Kirkwood, and J.M. Skowronski (Eds.), *Modelling and Management of Resources Under Uncertainty*, Lecture Notes in Biomathematics, Vol. 72. Springer-Verlag, Berlin. pp. 114-124.
- [249] Walters, C.J. 1987b. Users guide for GENEST: micro-computer stock assessment using Schnute's generalization of the Deriso delay-difference model. University of British Columbia. Vancouver.
- [250] Walters, C. 2000. Natural selection for predation avoidance tactics: implication for marine population and community dynamics. *Mar. Ecol. P.S.* 208:309-313.
- [251] Walters, C.J. and P.J. Bandy. 1972. Periodic harvests as a method of increasing big game yields. *J. Wildl. Mgmt.* 36:128-134.
- [252] Walters, C.J. and J.S. Collie. 1988. Is research on environmental factors useful to fisheries management?. *Can. J. Fish. Aquat. Sci.* 45:1848-1854.
- [253] Walters, C.J. and J.S. Collie. 1989. Design of an experimental program for groundfish management in the face of large uncertainty about stock size and production. In R.J. Beamish and G.A. MacFarlane (Ed.) *Effects of Ocean Variability on Recruitment and an Evaluation of Parameters Used in Stock Assessment Models*. Canadian Special Publications in Fisheries and Aquatic Sciences. No. 108. pp. 13-25.
- [254] Walters, C., V. Christensen and D. Pauly. 1997. Structuring dynamics models of exploited ecosystems from trophic mass-balance assessment. *Rev. in Fish Biology and Fisheries.* 7:139-172.
- [255] Watt, K.E.F. 1963. Dynamic programming, «Look ahead programming», and the strategy of insect pest control. *Can. Entomol.* 95:525-536.
- [256] Williams, I.D. and N.V.L. Polunin. Large-scale association between macroalgal cover and grazer density on mid-depth reefs in the Caribbean. *Coral Reefs* (in press).

- [257] Williams, I.D., N.V.C. Polunin and V. Hendrick. Limits to grazing by herbivorous fishes and the impact of low coral cover in macroalgal abundance on a coral reef in Belize. MEPS (in press).
- [258] Winters, G.H. and J.P. Wheeler. 1985. Interaction between stock area, stock abundance and catchability coefficient. Can. J. Fish. Aquat. Sci. 42:989-998.
- [259] Young, A.H., P. Tytler, and F.G.T. Holliday. 1976. New developments in ultrasonic fish tracking. Proc. R. Soc. Edin. 75(B):145-155.

---

## About the author

*Born in Barcelona in 1922, he studied at the University of Barcelona, where he graduated in natural sciences. After an initial contact with botany, in 1949 he formed part of a small group of scientists who intended to undertake marine studies in what would then become the Fishing Research Institute of the CSIC. He worked in Blanes, where he was in charge of a research group. In 1953 he defended his doctoral thesis at the University of Madrid. He was appointed research professor in 1972 when already working at the Institute in Barcelona, of which he was the director from 1983 until he retired. His specific field of research was the impact of fishing on the field of marine ecology. He showed a keen interest in the importance of the geomorphology of the environment, the environmental impact and the bioecological characteristics of the species exploited. Another aspect that defines his line of research is the importance given to socioeconomic factors in the development of the fishing activity.*

*He carried out his studies in the Mediterranean area and the eastern, central and southern Atlantic. His numerous scientific and informative publications led him to hold decision-making and advisory positions both in Catalonia and in the rest of Spain, and in particular in international spheres. He is a member of the Royal Academy of Sciences and Arts of Barcelona and of the Institute for Catalan Studies.*

*After fifty years of active work his research work continues.*